

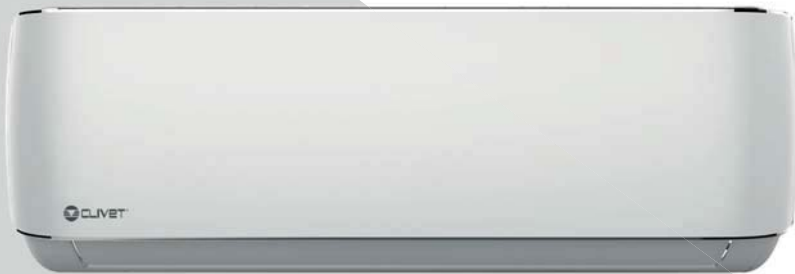

INSTALLATION AND OPERATING MANUAL

Cristallo R-32

SPLIT-TYPE ROOM AIR CONDITIONER



CRISTALLO (for MONOsplitted systems):
Series IM1-XY + MM1-Y 27M-70M

Nominal cooling capacity
from 2,6 to 7,0 kW



Change living home

Table of Contents

Installation Manual



IMPORTANT NOTE: Read this manual carefully before installing or operating your new air conditioning unit. Make sure to save this manual for future reference.

0	Safety Precautions.....	4
1	Accessories.....	6
2	Installation Summary - Indoor Unit.....	8
3	Unit Parts.....	10

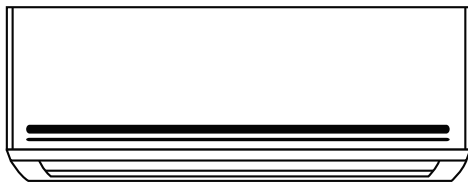
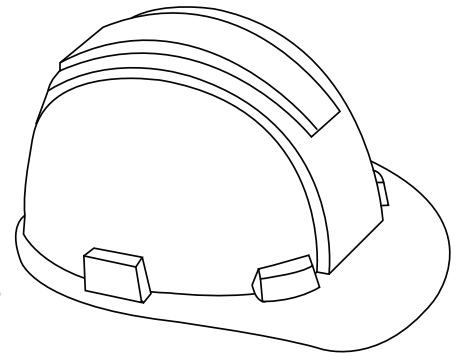

4	Indoor Unit Installation.....	11
	1. Select installation location.....	11
	2. Attach mounting plate to wall.....	12
	3. Drill wall hole for connective piping.....	12
	4. Prepare refrigerant piping.....	14
	5. Connect drain hose.....	15
	6. Connect signal cable.....	17
	7. Wrap piping and cables.....	18
	8. Connect indoor power wire.....	18
	9. Mount indoor unit.....	18

5	Outdoor Unit Installation...	20
	1. Select installation location.....	20
	2. Install drain joint.....	21
	3. Anchor outdoor unit.....	22
	4. Connect signal and power cables.....	23

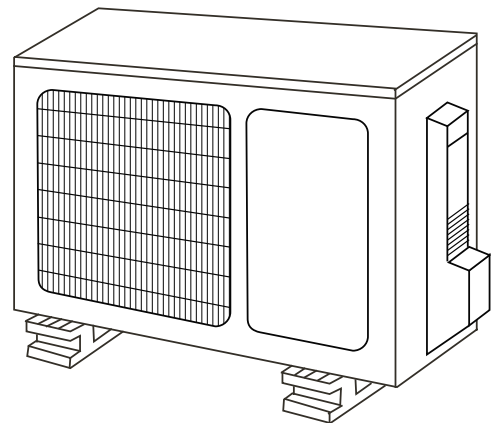

6 Refrigerant Piping Connection..... 25

A. Note on Pipe Length..... 25

B. Connection Instructions –Refrigerant Piping..... 25

1. Cut pipe..... 25

2. Remove burrs..... 26

3. Flare pipe ends..... 26

4. Connect pipes..... 27



Caution: Risk of fire

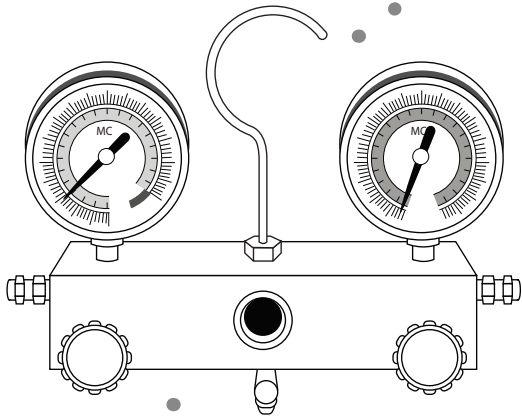
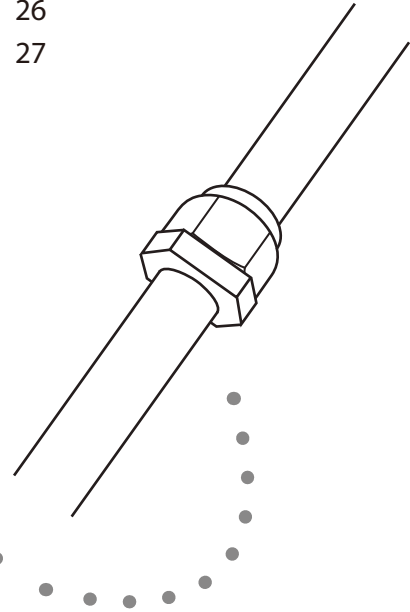

7 Air Evacuation..... 29

1. Evacuation Instructions..... 29

2. Note on Adding Refrigerant..... 30

8 Electrical and Gas Leak Checks..... 31

9 Test Run..... 32

10 European Disposal Guidelines..... 34

11 Information servicing 35

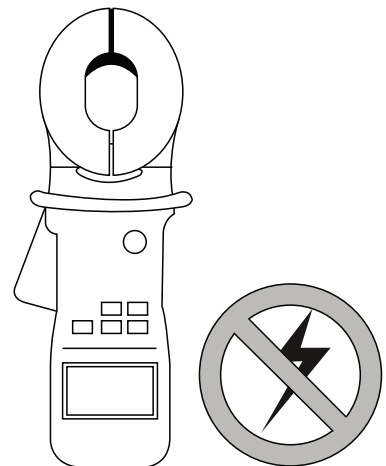

Safety Precautions

Read Safety Precautions Before Installation

Incorrect installation due to ignoring instructions can cause serious damage or injury. The seriousness of potential damage or injuries is classified as either a **WARNING** or **CAUTION**.



WARNING

This symbol indicates that ignoring instructions may cause death or serious injury.



CAUTION

This symbol indicates that ignoring instructions may cause moderate injury to your person, or damage to your unit or other property.



This symbol indicates that you must never perform the action indicated.



WARNING

- ⊘ Do not modify the length of the power supply cord or use an extension cord to power the unit. Do not share the electrical outlet with other appliances. Improper or insufficient power supply can cause fire or electrical shock.
 - ⊘ When connecting refrigerant piping, do not let substances or gases other than the specified refrigerant enter the unit. The presence of other gases or substances will lower the unit's capacity, and can cause abnormally high pressure in the refrigeration cycle. This can cause explosion and injury.
 - ⊘ Do not allow children to play with the air conditioner. Children must be supervised around the unit at all times.
1. Installation must be performed by an authorized dealer or specialist. Defective installation can cause water leakage, electrical shock, or fire.
 2. Installation must be performed according to the installation instructions. Improper installation can cause water leakage, electrical shock, or fire. (In North America, installation must be performed in accordance with the requirement of NEC and CEC by authorized personnel only.)
 3. Contact an authorized service technician for repair or maintenance of this unit.
 4. Only use the included accessories, parts, and specified parts for installation. Using non-standard parts can cause water leakage, electrical shock, fire, and can cause the unit to fail.
 5. Install the unit in a firm location that can support the unit's weight. If the chosen location cannot support the unit's weight, or the installation is not done properly, the unit may drop and cause serious injury and damage.
 6. Do not use means to accelerate the defrosting process or to clean, other than those recommended by the manufacturer.
 7. The appliance shall be stored in a room without continuously operating ignition sources (for example: open flames, an operating gas appliance or an operating electric heater)
 8. Do not pierce or burn.
 9. Appliance shall be stored in a well-ventilated area where the room size corresponds to the room area as specified for operation.
 10. Be aware that refrigerants may not contain an odour.

WARNING

11. For all electrical work, follow all local and national wiring standards, regulations, and the Installation Manual. You must use an independent circuit and single outlet to supply power. Do not connect other appliances to the same outlet. Insufficient electrical capacity or defects in electrical work can cause electrical shock or fire.
12. For all electrical work, use the specified cables. Connect cables tightly, and clamp them securely to prevent external forces from damaging the terminal. Improper electrical connections can overheat and cause fire, and may also cause shock.
13. All wiring must be properly arranged to ensure that the control board cover can close properly. If the control board cover is not closed properly, it can lead to corrosion and cause the connection points on the terminal to heat up, catch fire, or cause electrical shock.
14. In certain functional environments, such as kitchens, server rooms, etc., the use of specially designed air-conditioning units is highly recommended.
15. If the supply cord is damaged, it must be replaced by the manufacturer, its service agent or similarly qualified persons in order to avoid a hazard.
16. This appliance can be used by children aged from 8 years and above and persons with reduced Physical, sensory or mental capabilities or lack of experience and knowledge if they have been given supervision or instruction concerning use of the appliance in a safe way and understand the hazards involved. Children shall not play with the appliance. Cleaning and user maintenance shall not be made by children without supervision.

CAUTION

- ⊘ For units that have an auxiliary electric heater, do not install the unit within 1 meter (3 feet) of any combustible materials.
 - ⊘ Do not install the unit in a location that may be exposed to combustible gas leaks. If combustible gas accumulates around the unit, it may cause fire.
 - ⊘ Do not operate your air conditioner in a wet room such as a bathroom or laundry room. Too much exposure to water can cause electrical components to short circuit.
1. The product must be properly grounded at the time of installation, or electrical shock may occur.
 2. Install drainage piping according to the instructions in this manual. Improper drainage may cause water damage to your home and property.
 3. The appliance shall be stored so as to prevent mechanical damage from occurring.
 4. Any person who is involve with working on or breaking into a refrigerant circuit should hold a current valid certificate from an industry-accredited assessment authority, which authorizes their competence to handle refrigerants safely in accordance with an industry recognized assessment specification.







Note about Fluorinated Gasses

1. This air-conditioning unit contains fluorinated gasses. For specific information on the type of gas and the amount, please refer to the relevant label on the unit itself. Compliance with national gas regulations shall be observed.
2. Installation, service, maintenance and repair of this unit must be performed by a certified technician.
3. Product uninstallation and recycling must be performed by a certified technician.
4. If the system has a leak-detection system installed, it must be checked for leaks at least every 12 months. When the unit is checked for leaks, proper record-keeping of all checks is strongly recommended.

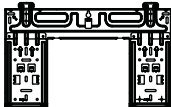
Accessories

1

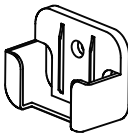
The air conditioning system comes with the following accessories. Use all of the installation parts and accessories to install the air conditioner. Improper installation may result in water leakage, electrical shock and fire, or cause the equipment to fail.

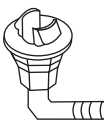
Name	Shape	Quantity	
Mounting plate		1	
Clip anchor		5	
Mounting plate fixing screw ST3.9 X 25		5	
Remote controller		1	
Fixing screw for remote controller holder ST2.9 x 10		2	Optional Parts
Remote controller holder		1	
Dry battery AAA.LR03		2	
Seal		1 (for cooling & heating models only)	
Drain joint			

Name	Shape	Quantity	
Installation and operating manual Owner's manual		1	
Connecting pipe assembly	Liquid side	Φ 6.35 (1/4 in)	Parts you must purchase. Consult the dealer about the pipe size.
		Φ 9.52 (3/8 in)	
	Gas side	Φ 9.52 (3/8 in)	
		Φ 12.7 (1/2 in)	
		Φ 16 (5/8 in)	

 **WARNING**

Appliance shall be stored in a well-ventilated area where the room size corresponds to the room area as specified for operation.

For R32 refrigerant models:

Appliance shall be installed, operated and stored in a room with a floor area larger than 4m².
Appliance shall not be installed in an unventilated space, if that space is smaller than 4m².

For R290 refrigerant models, the minimum room size needed:

≤9000Btu/h units: 13m²

>9000Btu/h and ≤12000Btu/h units: 17m²

>12000Btu/h and ≤18000Btu/h units: 26m²

>18000Btu/h and ≤24000Btu/h units: 35m²

Installation Summary - Indoor Unit

2

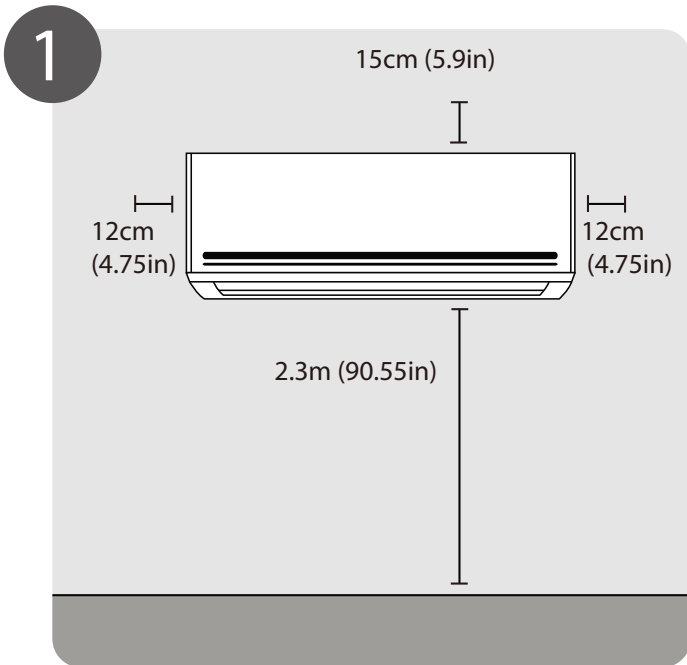

Select Installation Location
(Page 11)

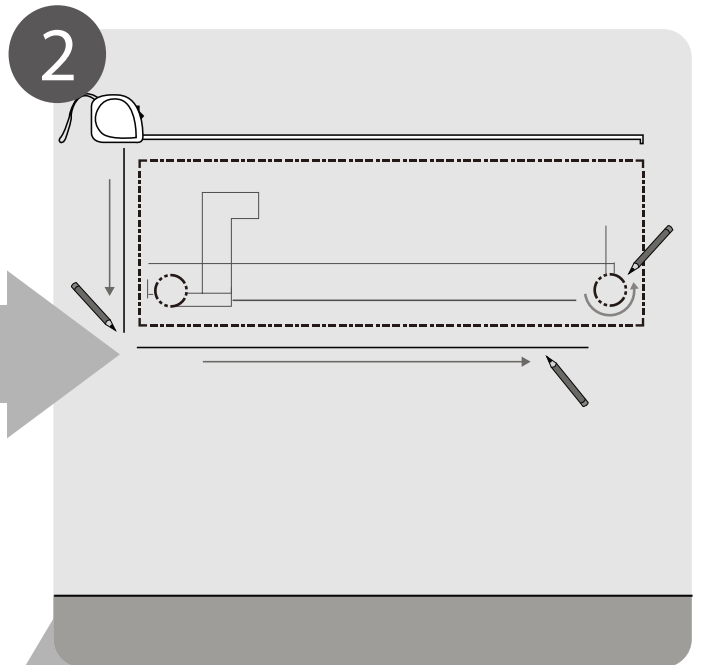

Determine Wall Hole Position
(Page 12)

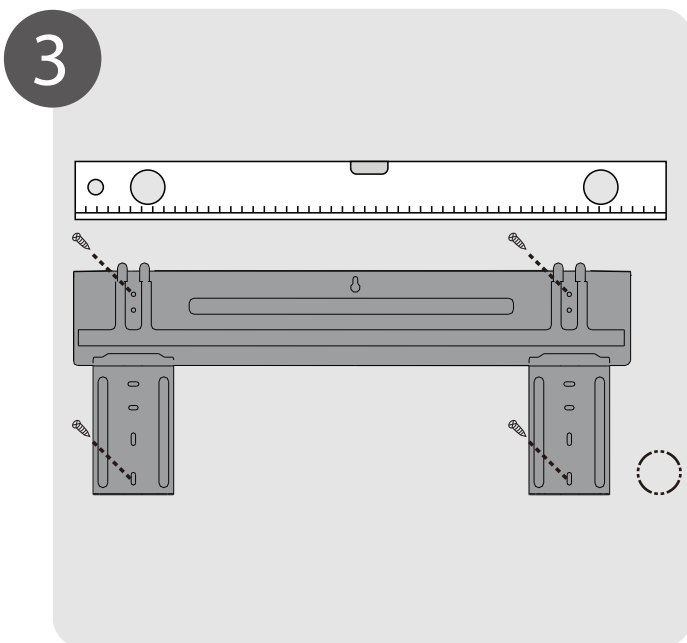

Attach Mounting Plate
(Page 12)

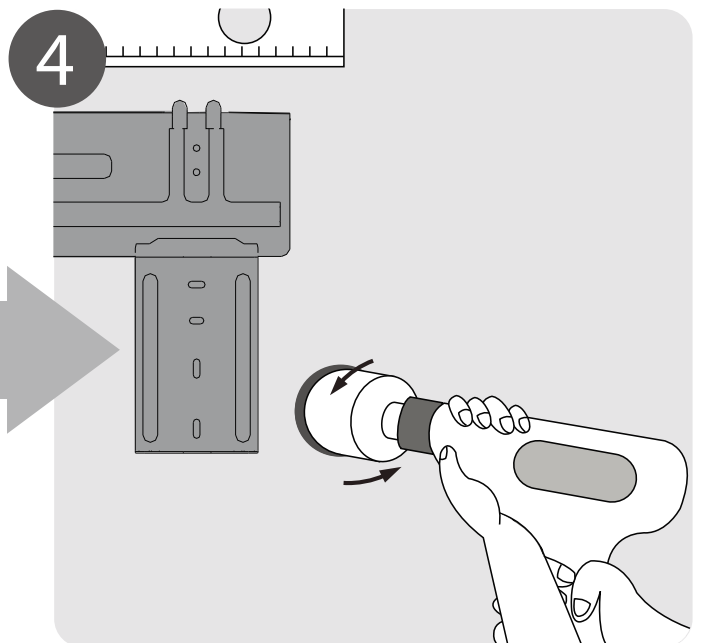

Drill Wall Hole
(Page 12)

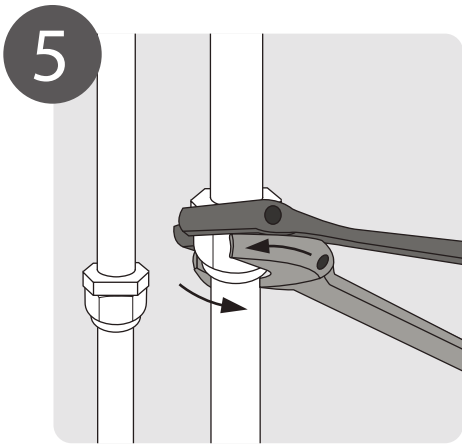

5
Connect Piping
(Page 25)

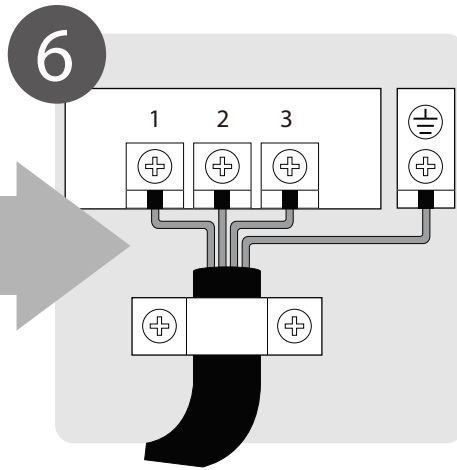

6
Connect Wiring
(Page 17)

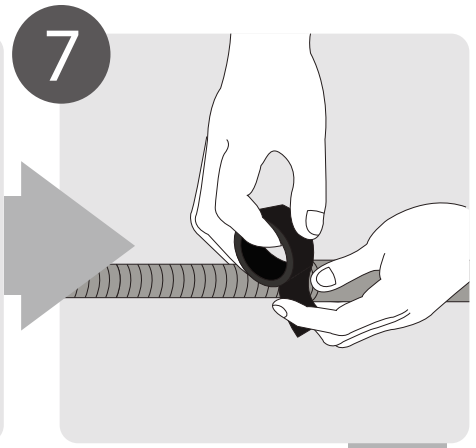

7
Prepare Refrigerant
piping
(Page 14)

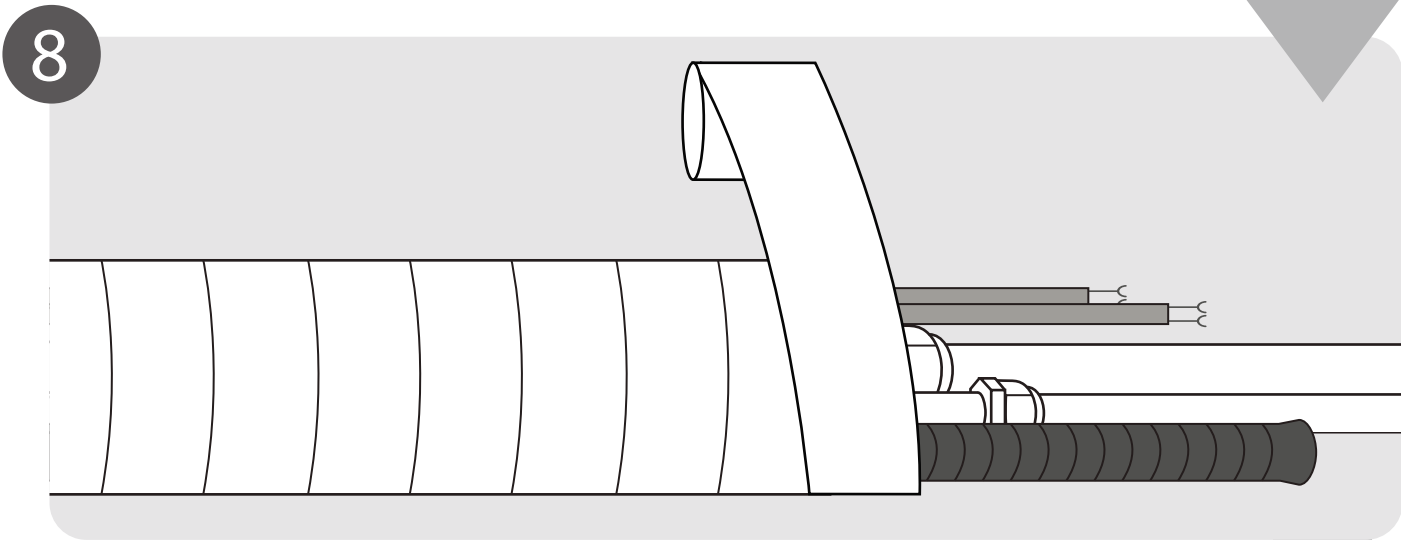

8
Wrap Piping and Cables
(Page 18)

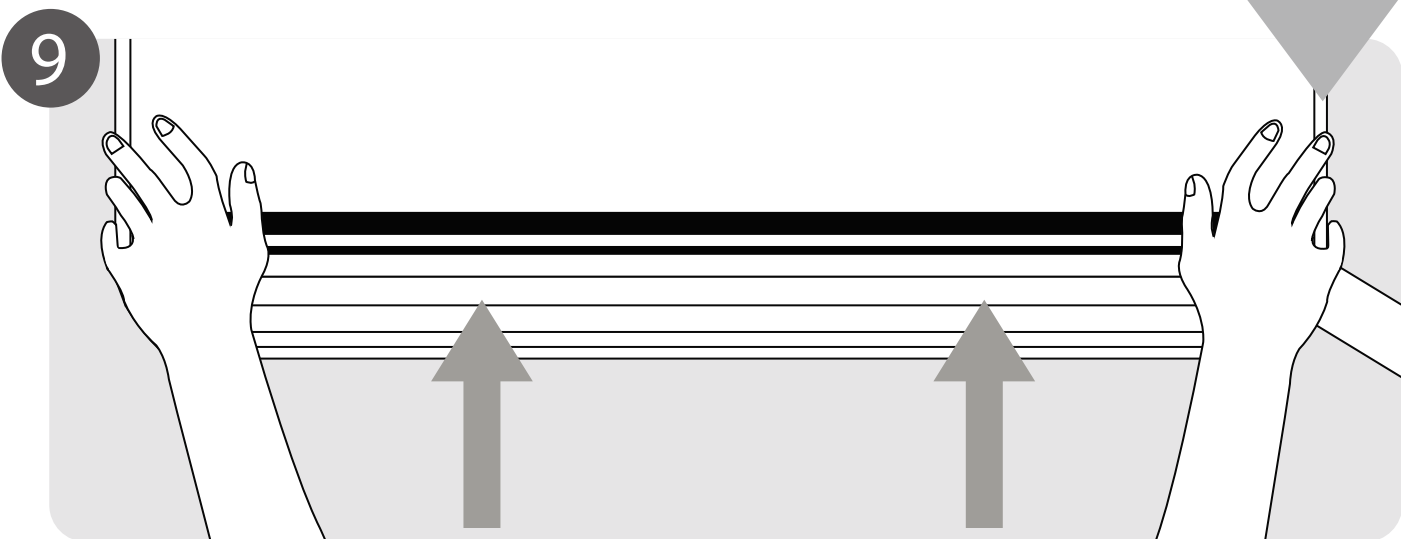

9
Mount Indoor Unit
(Page 18)

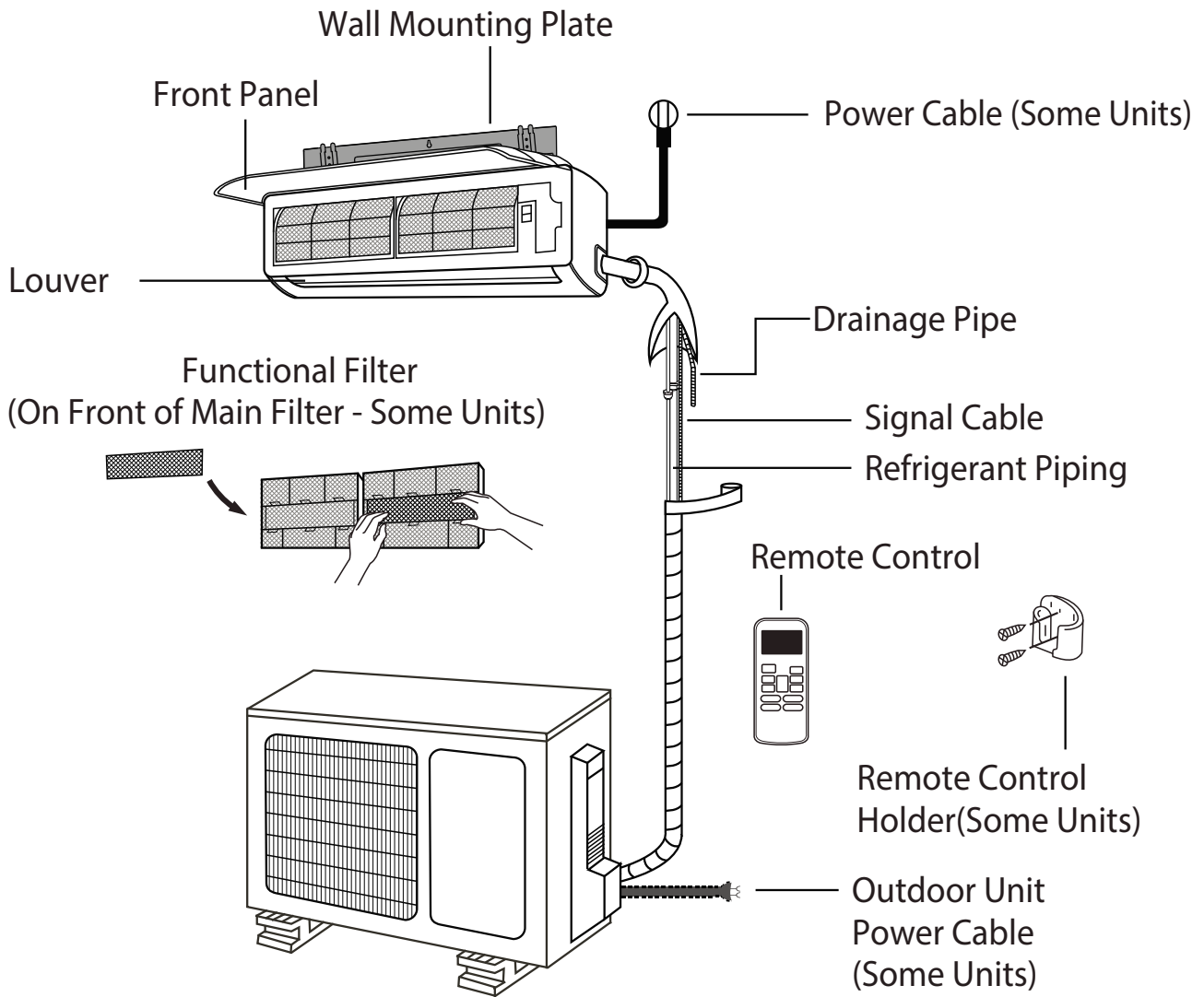

Fig. 3.1

NOTE ON ILLUSTRATIONS

Illustrations in this manual are for explanatory purposes. The actual shape of your indoor unit may be slightly different. The actual shape shall prevail.

Indoor Unit Installation

4

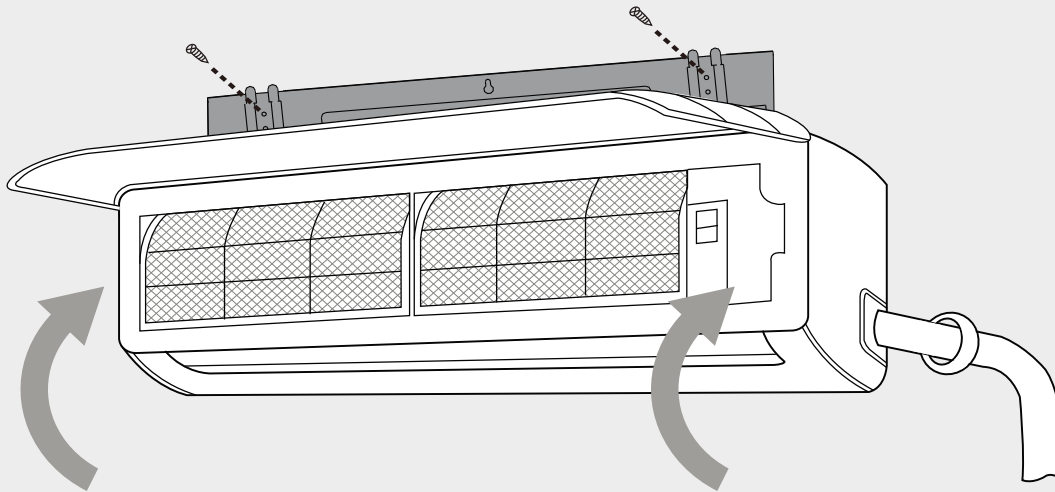

Fig. 3.1-a

Installation Instructions – Indoor Unit

PRIOR TO INSTALLATION

Before installing the indoor unit, refer to the label on the product box to make sure that the model number of the indoor unit matches the model number of the outdoor unit.

Step 1: Select installation location

Before installing the indoor unit, you must choose an appropriate location. The following are standards that will help you choose an appropriate location for the unit.

Proper installation locations meet the following standards:

- ☑ Good air circulation
- ☑ Convenient drainage
- ☑ Noise from the unit will not disturb other people
- ☑ Firm and solid—the location will not vibrate
- ☑ Strong enough to support the weight of the unit
- ☑ A location at least one meter from all other electrical devices (e.g., TV, radio, computer)

DO NOT install unit in the following locations:

- ⊘ Near any source of heat, steam, or combustible gas
- ⊘ Near flammable items such as curtains or clothing
- ⊘ Near any obstacle that might block air circulation
- ⊘ Near the doorway
- ⊘ In a location subject to direct sunlight

NOTE ABOUT WALL HOLE:

If there is no fixed refrigerant piping:

While choosing a location, be aware that you should leave ample room for a wall hole (see Drill wall hole for connective piping step) for the signal cable and refrigerant piping that connect the indoor and outdoor units. The default position for all piping is the right side of the indoor unit (while facing the unit). However, the unit can accommodate piping to both the left and right.

Refer to the following diagram to ensure proper distance from walls and ceiling:

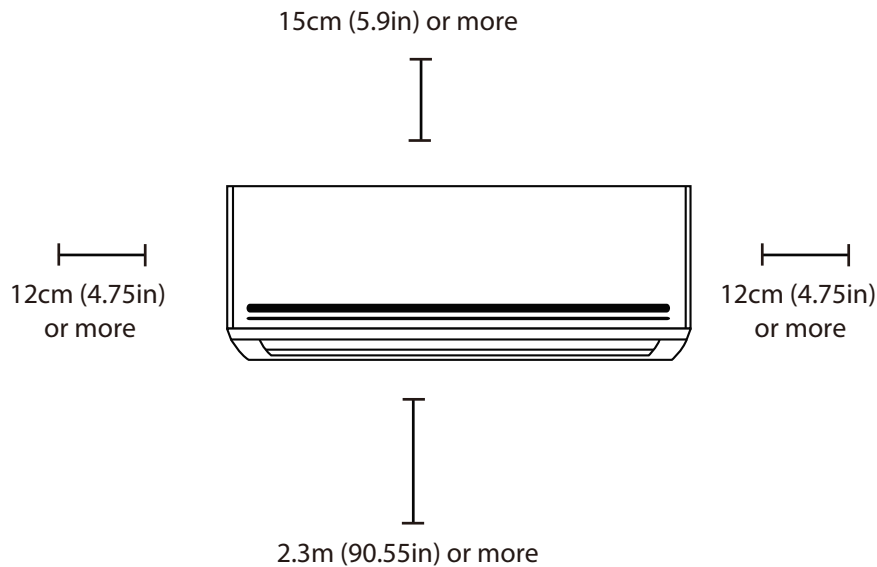

Fig. 3.1-b

Step 2: Attach mounting plate to wall

The mounting plate is the device on which you will mount the indoor unit.

1. Remove the screw that attaches the mounting plate to the back of the indoor unit.
2. Place the mounting plate against the wall in a location that meets the standards in the Select Installation Location step. (See Mounting Plate Dimensions for detailed information on mounting plate sizes.)
3. Drill holes for mounting screws in places that:
 - have studs and can support the weight of the unit
 - correspond to screw holes in the mounting plate
4. Secure the mounting plate to the wall with the screws provided.
5. Make sure that mounting plate is flat against the wall.

NOTE FOR CONCRETE OR BRICK WALLS:

If the wall is made of brick, concrete, or similar material, drill 5mm-diameter (0.2in-diameter) holes in the wall and insert the sleeve anchors provided. Then secure the mounting plate to the wall by tightening the screws directly into the clip anchors.

Step 3: Drill wall hole for connective piping

You must drill a hole in the wall for refrigerant piping, the drainage pipe, and the signal cable that will connect the indoor and outdoor units.

1. Determine the location of the wall hole based on the position of the mounting plate. Refer to Mounting Plate Dimensions on the next page to help you determine the optimal position. The wall hole should have a 65mm (2.5in) diameter at least, and at a slightly lower angle to facilitate drainage.
2. Using a 65-mm (2.5in) core drill, drill a hole in the wall. Make sure that the hole is drilled at a slight downward angle, so that the outdoor end of the hole is lower than the indoor end by about 5mm to 7mm (0.2-0.275in). This will ensure proper water drainage. (See Fig. 3.2)
3. Place the protective wall cuff in the hole. This protects the edges of the hole and will help seal it when you finish the installation process.

! CAUTION

When drilling the wall hole, make sure to avoid wires, plumbing, and other sensitive components.

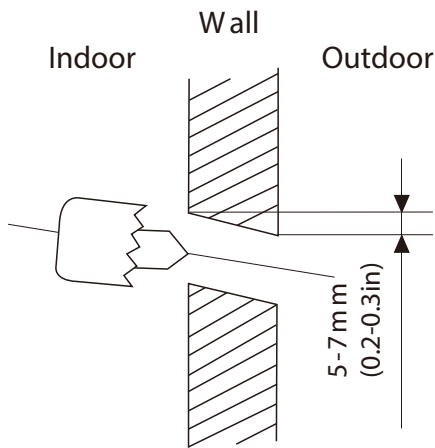
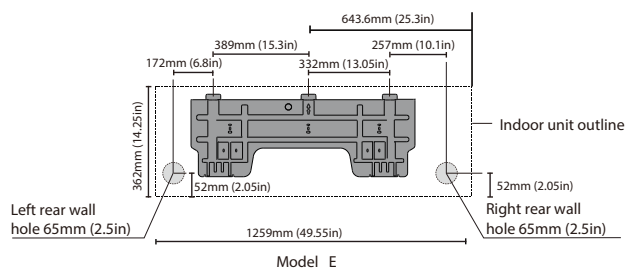
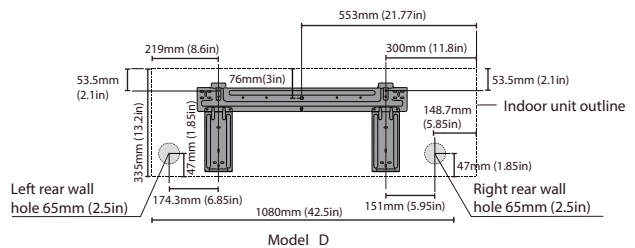
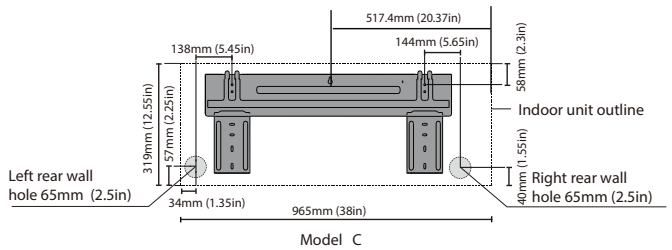
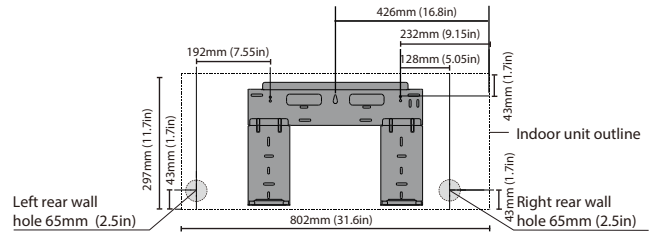
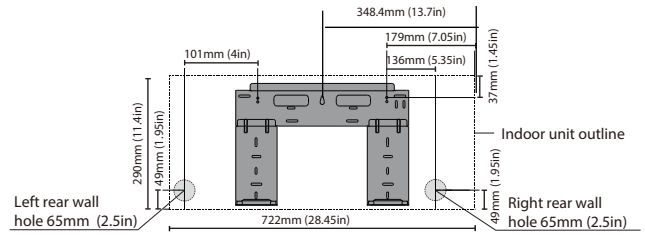

Fig. 3.2



MOUNTING PLATE DIMENSIONS

Different models have different mounting plates. In order to ensure that you have ample room to mount the indoor unit, the diagrams to the right show different types of mounting plates along with the following dimensions:

- Width of mounting plate
- Height of mounting plate
- Width of indoor unit relative to plate
- Height of indoor unit relative to plate
- Recommended position of wall hole (both to the left and right of mounting plate)
- Relative distances between screw holes

Correct orientation of Mounting Plate

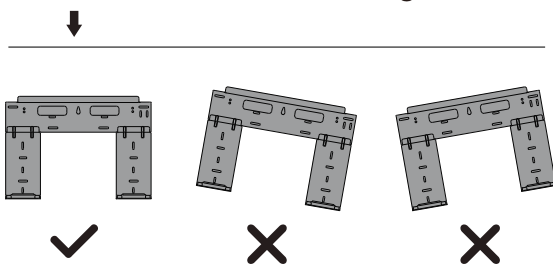

Step 4: Prepare refrigerant piping

The refrigerant piping is inside an insulating sleeve attached to the back of the unit. You must prepare the piping before passing it through the hole in the wall. Refer to the Refrigerant Piping Connection section of this manual for detailed instructions on pipe flaring and flare torque requirements, technique, etc.

1. Based on the position of the wall hole relative to the mounting plate, choose the side from which the piping will exit the unit.
2. If the wall hole is behind the unit, keep the knock-out panel in place. If the wall hole is to the side of the indoor unit, remove the plastic knock-out panel from that side of the unit. (See Fig. 3.3). This will create a slot through which your piping can exit the unit. Use needle nose pliers if the plastic panel is too difficult to remove by hand.

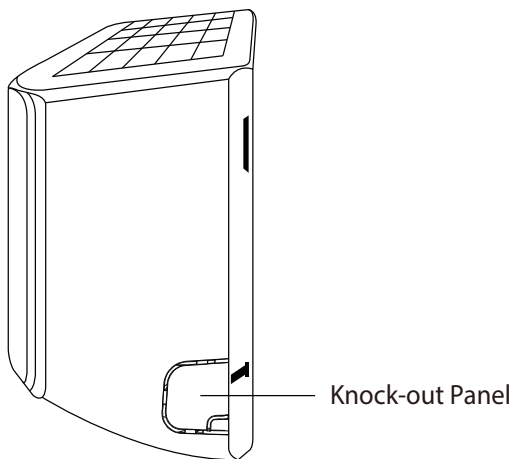

Fig. 3.3

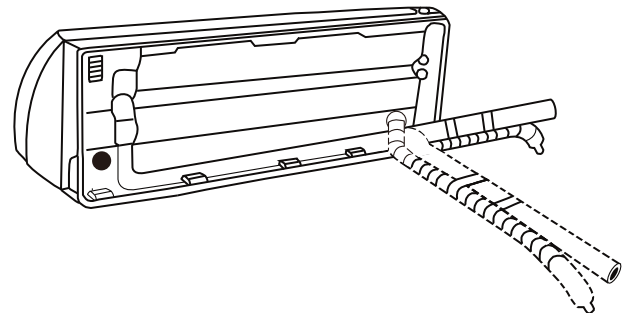
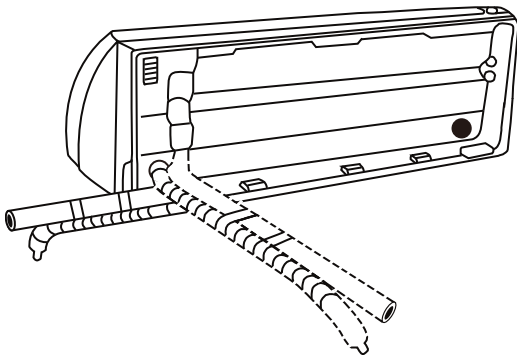

Fig. 3.4

3. Use scissors to cut down the length of the insulating sleeve to reveal about 15cm (6in) of the refrigerant piping. This serves two purposes:
 - To facilitate the Refrigerant Piping Connection process
 - To facilitate Gas Leak Checks and enable you to check for dents
4. If existing connective piping is already embedded in the wall, proceed directly to the Connect Drain Hose step. If there is no embedded piping, connect the indoor unit's refrigerant piping to the connective piping that will join the indoor and outdoor units. Refer to the Refrigerant Piping Connection section of this manual for detailed instructions.
5. Based on the position of the wall hole relative to the mounting plate, determine the necessary angle of your piping.
6. Grip the refrigerant piping at the base of the bend.
7. Slowly, with even pressure, bend the piping towards the hole. **Do not** dent or damage the piping during the process.

NOTE ON PIPING ANGLE

Refrigerant piping can exit the indoor unit from four different angles:

- Left-hand side
- Left rear
- Right-hand side
- Right rear

Refer to Fig. 3.4 for details.

! CAUTION

Be extremely careful not to dent or damage the piping while bending them away from the unit. Any dents in the piping will affect the unit's performance.

Step 5: Connect drain hose

By default, the drain hose is attached to the left-hand side of unit (when you're facing the back of the unit). However, it can also be attached to the right-hand side.

1. To ensure proper drainage, attach the drain hose on the same side that your refrigerant piping exits the unit.
2. Attach drain hose extension (purchased separately) to the end of drain hose.
3. Wrap the connection point firmly with Teflon tape to ensure a good seal and to prevent leaks.
4. For the portion of the drain hose that will remain indoors, wrap it with foam pipe insulation to prevent condensation.
5. Remove the air filter and pour a small amount of water into the drain pan to make sure that water flows from the unit smoothly.

NOTE ON DRAIN HOSE PLACEMENT

Make sure to arrange the drain hose according to Fig. 3.5 .

- ⊘ DO NOT kink the drain hose.
- ⊘ DO NOT create a water trap.
- ⊘ DO NOT put the end of drain hose in water or a container that will collect water.

PLUG THE UNUSED DRAIN HOLE

To prevent unwanted leaks you must plug the unused drain hole with the rubber plug provided.

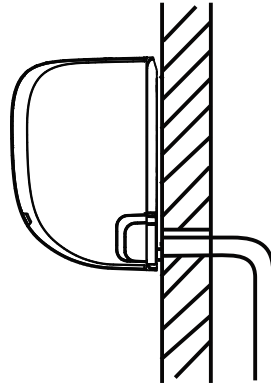

Fig. 3.5

CORRECT
Make sure there are no kinks or dent in drain hose to ensure proper drainage.



NOT CORRECT
Kinks in the drain hose will create water traps.

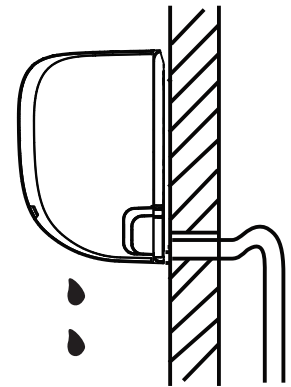

Fig. 3.6

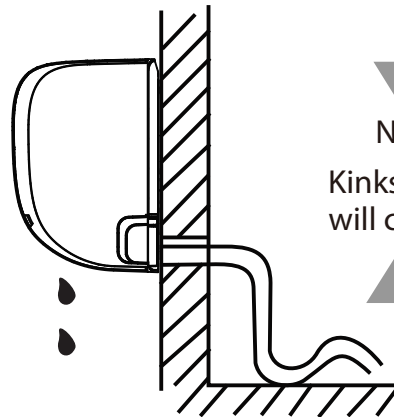

Fig. 3.7

NOT CORRECT
Kinks in the drain hose will create water traps.

NOT CORRECT
Do not place the end of the drain hose in water or in containers that collect water. This will prevent proper drainage.

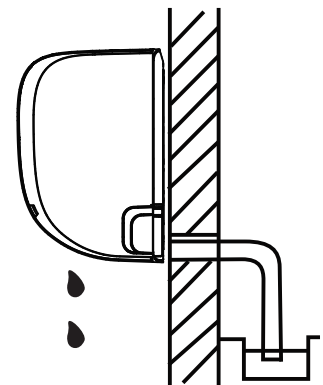

Fig. 3.8

 **BEFORE PERFORMING ELECTRICAL WORK, READ THESE REGULATIONS**

1. All wiring must comply with local and national electrical codes, and must be installed by a licensed electrician.
2. All electrical connections must be made according to the Electrical Connection Diagram located on the panels of the indoor and outdoor units.
3. If there is a serious safety issue with the power supply, stop work immediately. Explain your reasoning to the client, and refuse to install the unit until the safety issue is properly resolved.
4. Power voltage should be within 90-100% of rated voltage. Insufficient power supply can cause malfunction, electrical shock, or fire.
5. If connecting power to fixed wiring, install a surge protector and main power switch with a capacity of 1.5 times the maximum current of the unit.
6. If connecting power to fixed wiring, a switch or circuit breaker that disconnects all poles and has a contact separation of at least 1/8in (3mm) must be incorporated in the fixed wiring. The qualified technician must use an approved circuit breaker or switch.
7. Only connect the unit to an individual branch circuit outlet. Do not connect another appliance to that outlet.
8. Make sure to properly ground the air conditioner.
9. Every wire must be firmly connected. Loose wiring can cause the terminal to overheat, resulting in product malfunction and possible fire.
10. Do not let wires touch or rest against refrigerant tubing, the compressor, or any moving parts within the unit.
11. If the unit has an auxiliary electric heater, it must be installed at least 1 meter (40in) away from any combustible materials.

 **WARNING**

BEFORE PERFORMING ANY ELECTRICAL OR WIRING WORK , TURN OFF THE MAIN POWER TO THE SYSTEM .

Step 6: Connect signal cable

The signal cable enables communication between the indoor and outdoor units. You must first choose the right cable size before preparing it for connection.

Cable Types

- Indoor Power Cable (if applicable): H05VV-F or H05V2V2-F
- Outdoor Power Cable: H07RN-F
- Signal Cable: H07RN-F

Minimum Cross-Sectional Area of Power and Signal Cables

North America

Appliance Amps (A)	AWG
10	18
13	16
18	14
25	12
30	10

Other Regions

Rated Current of Appliance (A)	Nominal Cross-Sectional Area (mm ²)
> 3 and ≤ 6	0.75
> 6 and ≤ 10	1
> 10 and ≤ 16	1.5
> 16 and ≤ 25	2.5
> 25 and ≤ 32	4
> 32 and ≤ 40	6

CHOOSE THE RIGHT CABLE SIZE

The size of the power supply cable, signal cable, fuse, and switch needed is determined by the maximum current of the unit. The maximum current is indicated on the nameplate located on the side panel of the unit. Refer to this nameplate to choose the right cable, fuse, or switch.

TAKE NOTE OF FUSE SPECIFICATIONS

The air conditioner's circuit board (PCB) is designed with a fuse to provide overcurrent protection. The specifications of the fuse

are printed on the circuit board, such as:

Indoor unit: T5A/250VAC

Outdoor unit:

T20A/250VAC(≤18000Btu/h units)

T30A/250VAC(>18000Btu/h units)

NOTE: The fuse is made of ceramic.

1. Prepare the cable for connection:
 - a. Using wire strippers, strip the rubber jacket from both ends of signal cable to reveal about 40mm (1.57in) of the wires inside.
 - b. Strip the insulation from the ends of the wires.
 - c. Using wire crimper, crimp u-type lugs on the ends of the wires.

PAY ATTENTION TO LIVE WIRE

While crimping wires, make sure you clearly distinguish the Live ("L") Wire from other wires.

2. Open front panel of the indoor unit.
3. Using a screwdriver, open the wire box cover on the right side of the unit. This will reveal the terminal block.

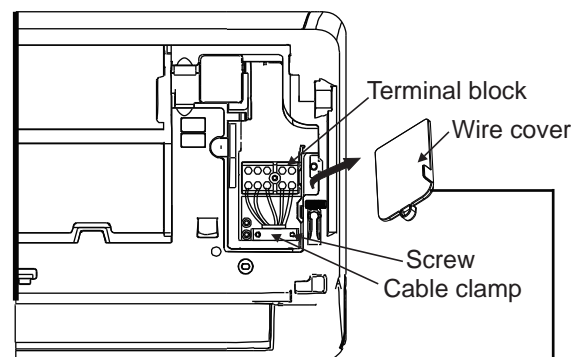

Fig. 3.9

The Wiring Diagram is located on the inside of the indoor unit's wire cover.

WARNING

ALL WIRING MUST PERFORMED STRICTLY IN ACCORDANCE WITH THE WIRING DIAGRAM LOCATED ON THE INSIDE OF THE INDOOR UNIT S WIRE COVER.

4. Unscrew the cable clamp below the terminal block and place it to the side.

5. Facing the back of the unit, remove the plastic panel on the bottom left-hand side.
6. Feed the signal wire through this slot, from the back of the unit to the front.
7. Facing the front of the unit, match the wire colors with the labels on the terminal block, connect the u-lug and and firmly screw each wire to its corresponding terminal.

! CAUTION

DO NOT MIX UP LIVE AND NULL WIRES

This is dangerous, and can cause the air conditioning unit to malfunction.

8. After checking to make sure every connection is secure, use the cable clamp to fasten the signal cable to the unit. Screw the cable clamp down tightly.
9. Replace the wire cover on the front of the unit, and the plastic panel on the back.

! NOTE ABOUT WIRING

THE WIRING CONNECTION PROCESS MAY DIFFER SLIGHTLY BETWEEN UNITS.

Step 7: Wrap piping and cables

Before passing the piping, drain hose, and the signal cable through the wall hole, you must bundle them together to save space, protect them, and insulate them.

1. Bundle the drain hose, refrigerant pipes, and signal cable according to Fig. 3.10.

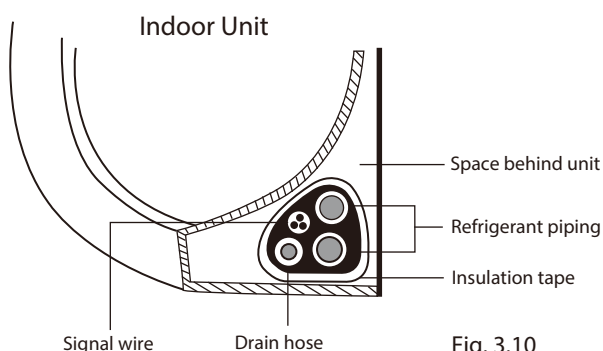

Fig. 3.10

DRAIN HOSE MUST BE ON BOTTOM

Make sure that the drain hose is at the bottom of the bundle. Putting the drain hose at the top of the bundle can cause the drain pan to overflow, which can lead to fire or water damage.

DO NOT INTERTWINE SIGNAL CABLE WITH OTHER WIRES

While bundling these items together, do not intertwine or cross the signal cable with any other wiring.

2. Using adhesive vinyl tape, attach the drain hose to the underside of the refrigerant pipes.
3. Using insulation tape, wrap the signal wire, refrigerant pipes, and drain hose tightly together. Double-check that all items are bundled in accordance with Fig. 3.10.

DO NOT WRAP ENDS OF PIPING

When wrapping the bundle, keep the ends of the piping unwrapped. You need to access them to test for leaks at the end of the installation process (refer to Electrical Checks and Leak Checks section of this manual).

Step 8: Mount indoor unit

If you installed new connective piping to the outdoor unit, do the following:

1. If you have already passed the refrigerant piping through the hole in the wall, proceed to Step 4.
2. Otherwise, double-check that the ends of the refrigerant pipes are sealed to prevent dirt or foreign materials from entering the pipes.
3. Slowly pass the wrapped bundle of refrigerant pipes, drain hose, and signal wire through the hole in the wall.
4. Hook the top of the indoor unit on the upper hook of the mounting plate.
5. Check that unit is hooked firmly on mounting by applying slight pressure to the left and right-hand sides of the unit. The unit should not jiggle or shift.
6. Using even pressure, push down on the bottom half of the unit. Keep pushing down until the unit snaps onto the hooks along the bottom of the mounting plate.
7. Again, check that the unit is firmly mounted by applying slight pressure to the left and the right-hand sides of the unit.

If refrigerant piping is already embedded in the wall, do the following:

1. Hook the top of the indoor unit on the upper hook of the mounting plate.
2. Use a bracket or wedge to prop up the unit, giving you enough room to connect the refrigerant piping, signal cable, and drain hose. Refer to Fig. 3.11 for an example.

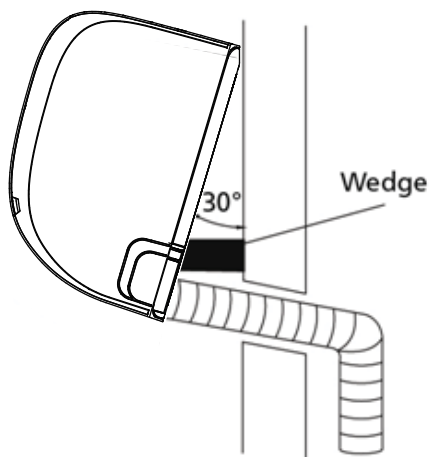
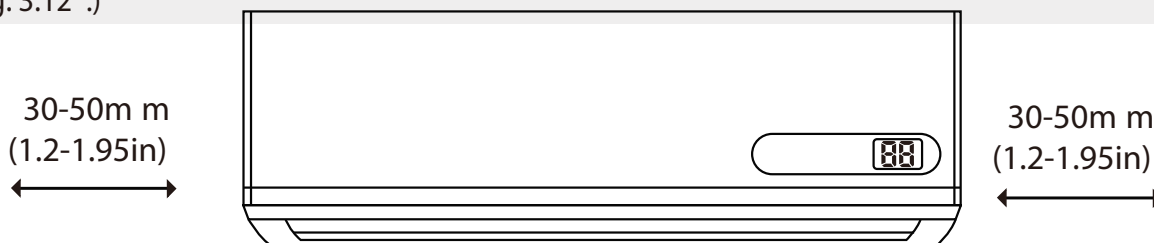

Fig. 3.11

3. Connect drain hose and refrigerant piping (refer to Refrigerant Piping Connection section of this manual for instructions).
4. Keep pipe connection point exposed to perform the leak test (refer to Electrical Checks and Leak Checks section of this manual).
5. After the leak test, wrap the connection point with insulation tape.
6. Remove the bracket or wedge that is propping up the unit.
7. Using even pressure, push down on the bottom half of the unit. Keep pushing down until the unit snaps onto the hooks along the bottom of the mounting plate.

UNIT IS ADJUSTABLE

Keep in mind that the hooks on the mounting plate are smaller than the holes on the back of the unit. If you find that you don't have ample room to connect embedded pipes to the indoor unit, the unit can be adjusted left or right by about 30-50mm (1.25-1.95in), depending on the model. (See Fig. 3.12 .)



Move to left or right

Fig. 3.12

Outdoor Unit Installation

5

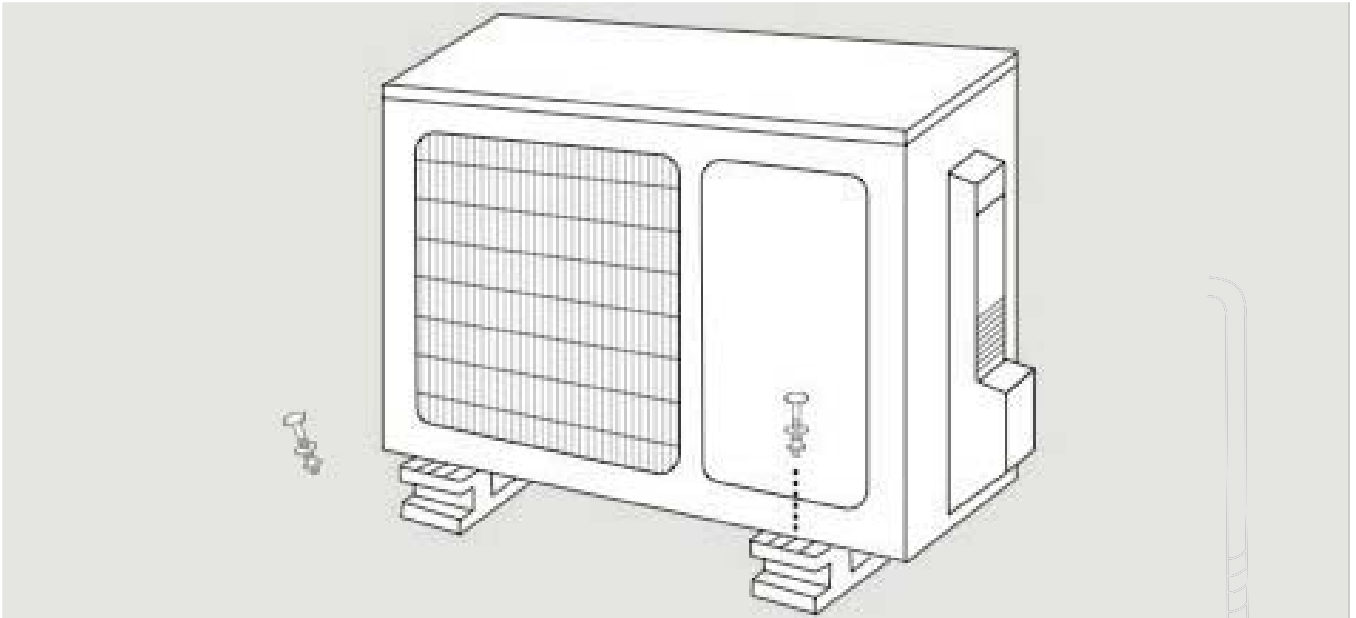

Installation Instructions – Outdoor Unit

Step 1: Select installation location

Before installing the outdoor unit, you must choose an appropriate location. The following are standards that will help you choose an appropriate location for the unit.

Proper installation locations meet the following standards:

- ☑ Meets all spatial requirements shown in Installation Space Requirements (Fig. 4.1)
- ☑ Good air circulation and ventilation
- ☑ Firm and solid—the location can support the unit and will not vibrate
- ☑ Noise from the unit will not disturb others
- ☑ Protected from prolonged periods of direct sunlight or rain

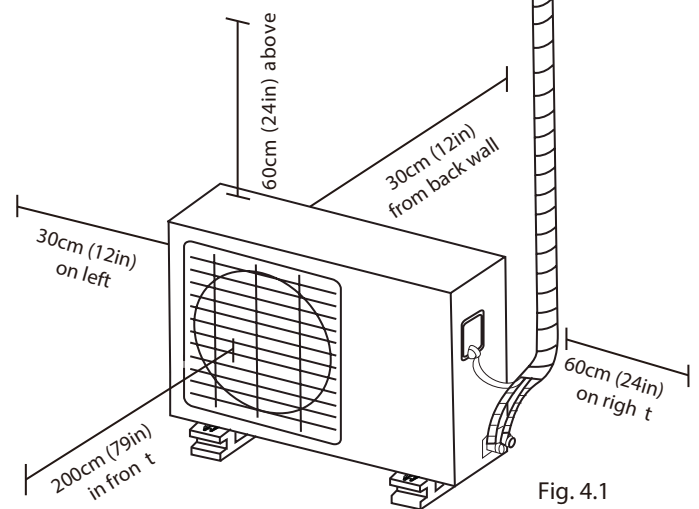

Fig. 4.1

DO NOT install unit in the following locations:

- ⊘ Near an obstacle that will block air inlets and outlets
- ⊘ Near a public street, crowded areas, or where noise from the unit will disturb others
- ⊘ Near animals or plants that will be harmed by hot air discharge
- ⊘ Near any source of combustible gas
- ⊘ In a location that is exposed to large amounts of dust
- ⊘ In a location exposed to a excessive amounts of salty air

SPECIAL CONSIDERATIONS FOR EXTREME WEATHER

If the unit is exposed to heavy wind:

Install unit so that air outlet fan is at a 90° angle to the direction of the wind. If needed, build a barrier in front of the unit to protect it from extremely heavy winds.

See Fig. 4.2 and Fig. 4.3 below.

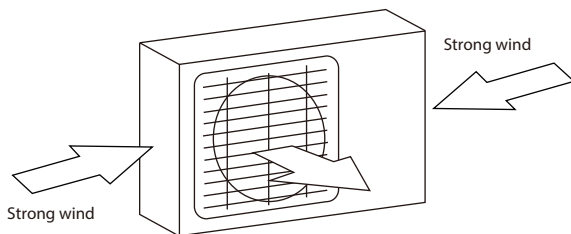

Fig. 4.2

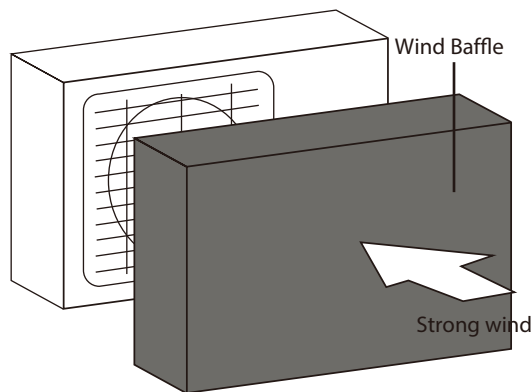

Fig. 4.3

If the unit is frequently exposed to heavy rain or snow:

Build a shelter above the unit to protect it from the rain or snow. Be careful not to obstruct air flow around the unit.

If the unit is frequently exposed to salty air (seaside):

Use outdoor unit that is specially designed to resist corrosion.

Step 2: Install drain joint

Heat pump units require a drain joint. Before bolting the outdoor unit in place, you must install the drain joint at the bottom of the unit. Note that there are two different types of drain joints depending on the type of outdoor unit.

If the drain joint comes with a rubber seal (see Fig. 4.4 - A), do the following:

1. Fit the rubber seal on the end of the drain joint that will connect to the outdoor unit.
2. Insert the drain joint into the hole in the base pan of the unit.
3. Rotate the drain joint 90° until it clicks in place facing the front of the unit.
4. Connect a drain hose extension (not included) to the drain joint to redirect water from the unit during heating mode.

If the drain joint doesn't come with a rubber seal (see Fig. 4.4 - B), do the following:

1. Insert the drain joint into the hole in the base pan of the unit. The drain joint will click in place.
2. Connect a drain hose extension (not included) to the drain joint to redirect water from the unit during heating mode.

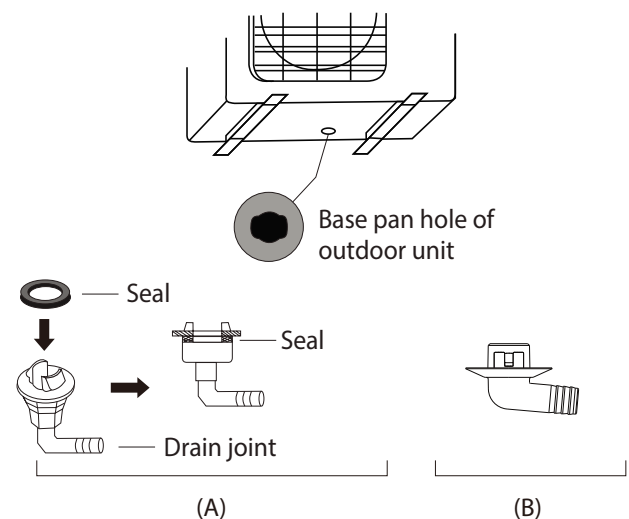

Fig. 4.4

! IN COLD CLIMATES

In cold climates, make sure that the drain hose is as vertical as possible to ensure swift water drainage. If water drains too slowly, it can freeze in the hose and flood the unit.

Step 3: Anchor outdoor unit

The outdoor unit can be anchored to the ground or to a wall-mounted bracket.

UNIT MOUNTING DIMENSIONS

The following is a list of different outdoor unit sizes and the distance between their mounting feet. Prepare the installation base of the unit according to the dimensions below.

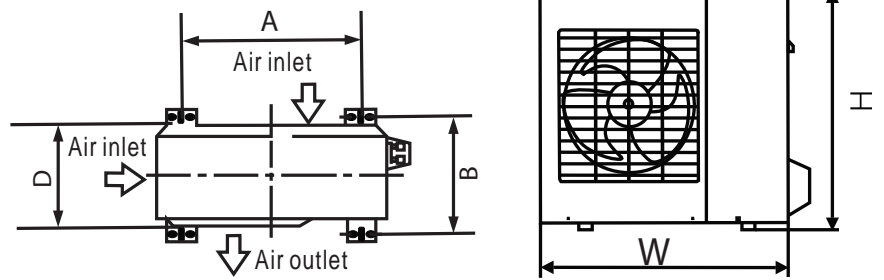

Fig. 4.5

Outdoor Unit Dimensions (mm) W x H x D	Mounting Dimensions	
	Distance A (mm)	Distance B (mm)
770x555x300 (30.3"x21.85"x11.81")	487 (19.2")	298 (11.73")
800x554x333 (31.5"x21.8"x13.1")	514 (20.24")	340 (13.39")
845x700x540 (33.25"x21.25"x12.6")	560 (22")	335 (13.2")

If you will install the unit on the ground or on a concrete mounting platform, do the following:

1. Mark the positions for four expansion bolts based on dimensions in the Unit Mounting Dimensions chart.
2. Pre-drill holes for expansion bolts.
3. Clean concrete dust away from holes.
4. Place a nut on the end of each expansion bolt.
5. Hammer expansion bolts into the pre-drilled holes.

6. Remove the nuts from expansion bolts, and place outdoor unit on bolts.
7. Put washer on each expansion bolt, then replace the nuts.
8. Using a wrench, tighten each nut until snug.

WARNING

WHEN DRILLING INTO CONCRETE, EYE PROTECTION IS RECOMMENDED AT ALL TIMES.

If you will install the unit on a wall-mounted bracket, do the following:

CAUTION

Before installing a wall-mounted unit, make sure that the wall is made of solid brick, concrete, or of similarly strong material. The wall must be able to support at least four times the weight of the unit.

1. Mark the position of bracket holes based on dimensions in the Unit Mounting Dimensions chart.
2. Pre-drill the holes for the expansion bolts.
3. Clean dust and debris away from holes.
4. Place a washer and nut on the end of each expansion bolt.
5. Thread expansion bolts through holes in mounting brackets, put mounting brackets in position, and hammer expansion bolts into the wall.
6. Check that the mounting brackets are level.
7. Carefully lift unit and place its mounting feet on brackets.
8. Bolt the unit firmly to the brackets.

TO REDUCE VIBRATIONS OF WALL-MOUNTED UNIT

If allowed, you can install the wall-mounted unit with rubber gaskets to reduce vibrations and noise.

Step 4: Connect signal and power cables

The outside unit's terminal block is protected by an electrical wiring cover on the side of the unit. A comprehensive wiring diagram is printed on the inside of the wiring cover.



BEFORE PERFORMING ELECTRICAL WORK, READ THESE REGULATIONS

1. All wiring must comply with local and national electrical codes, and must be installed by a licensed electrician.
2. All electrical connections must be made according to the Electrical Connection Diagram located on the side panels of the indoor and outdoor units.
3. If there is a serious safety issue with the power supply, stop work immediately. Explain your reasoning to the client, and refuse to install the unit until the safety issue is properly resolved.
4. Power voltage should be within 90-100% of rated voltage. Insufficient power supply can cause electrical shock or fire.
5. If connecting power to fixed wiring, install a surge protector and main power switch with a capacity of 1.5 times the maximum current of the unit.
6. If connecting power to fixed wiring, a switch or circuit breaker that disconnects all poles and has a contact separation of at least 1/8in (3mm) must be incorporated in the fixed wiring. The qualified technician must use an approved circuit breaker or switch.
7. Only connect the unit to an individual branch circuit outlet. Do not connect another appliance to that outlet.
8. Make sure to properly ground the air conditioner.
9. Every wire must be firmly connected. Loose wiring can cause the terminal to overheat, resulting in product malfunction and possible fire.
10. Do not let wires touch or rest against refrigerant tubing, the compressor, or any moving parts within the unit.
11. If the unit has an auxiliary electric heater, it must be installed at least 1 meter (40in) away from any combustible materials.

! WARNING

BEFORE PERFORMING ANY ELECTRICAL OR WIRING WORK, TURN OFF THE MAIN POWER TO THE SYSTEM.

1. Prepare the cable for connection:

USE THE RIGHT CABLE

- Indoor Power Cable (if applicable): H05VV-F or H05V2V2-F
- Outdoor Power Cable: H07RN-F
- Signal Cable: H07RN-F

Minimum Cross-Sectional Area of Power and Signal Cables

North America

Appliance Amps (A)	AWG
10	18
13	16
18	14
25	12
30	10

Other Regions

Rated Current of Appliance (A)	Nominal Cross-Sectional Area (mm ²)
> 3 and ≤ 6	0.75
> 6 and ≤ 10	1
> 10 and ≤ 16	1.5
> 16 and ≤ 25	2.5
> 25 and ≤ 32	4
> 32 and ≤ 40	6

- Using wire strippers, strip the rubber jacket from both ends of cable to reveal about 40mm (1.57in) of the wires inside.
- Strip the insulation from the ends of the wires.
- Using a wire crimper, crimp u-lugs on the ends of the wires.

PAY ATTENTION TO LIVE WIRE

While crimping wires, make sure you clearly distinguish the Live ("L") Wire from other wires.

! WARNING

ALL WIRING MUST PERFORMED STRICTLY IN ACCORDANCE WITH THE WIRING DIRGRAM LOCATED INSIDE THE OUTDOOR UNIT'S WIRE COVER.

- Unscrew the electrical wiring cover and remove it.
- Unscrew the cable clamp below the terminal block and place it to the side.
- Match the wire colors/labels with the labels on the terminal block, and firmly screw the u-lug of each wire to its corresponding terminal.
- After checking to make sure every connection is secure, loop the wires around to prevent rain water from flowing into the terminal.
- Using the cable clamp, fasten the cable to the unit. Screw the cable clamp down tightly.
- Insulate unused wires with PVC electrical tape. Arrange them so that they do not touch any electrical or metal parts.
- Replace the wire cover on the side of the unit, and screw it in place.

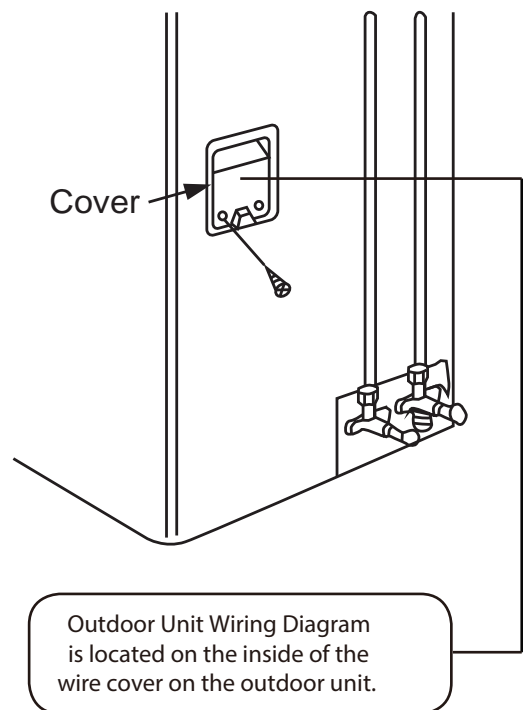
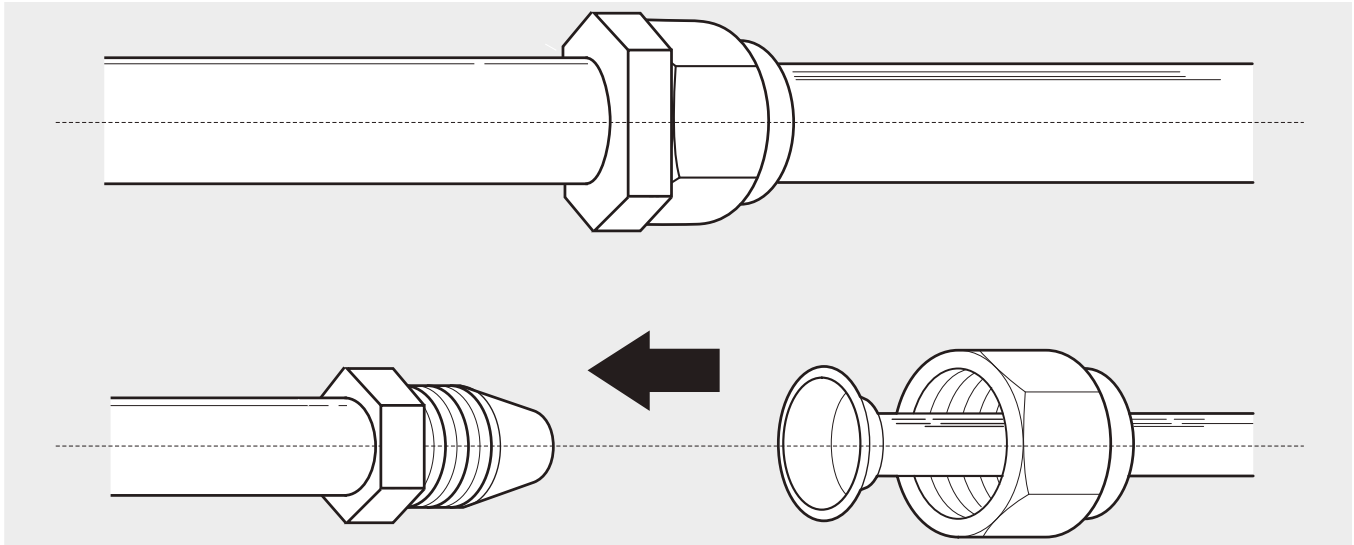

Fig. 4.6

Refrigerant Piping Connection

6



Note on Pipe Length

The length of refrigerant piping will affect the performance and energy efficiency of the unit. Nominal efficiency is tested on units with a pipe length of 5 meters (16.5ft). For special tropical area, the maximum length of refrigerant pipe should not exceed 10 meters(32.8ft) and no refrigerant can be added(For R290 refrigerant models).

Connection Instructions – Refrigerant Piping

Step 1: Cut pipes

When preparing refrigerant pipes, take extra care to cut and flare them properly. This will ensure efficient operation and minimize the need for future maintenance. The pipe connection points must be placed outside of room.

1. Measure the distance between the indoor and outdoor units.

2. Using a pipe cutter, cut the pipe a little longer than the measured distance.
3. Make sure that the pipe is cut at a perfect 90° angle. Refer to Fig. 5.1 for bad cut examples.

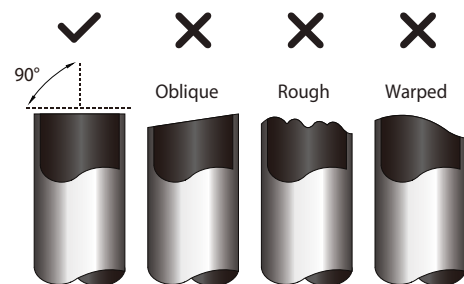

Fig. 5.1

! DO NOT DEFORM PIPE WHILE CUTTING

Be extra careful not to damage, dent, or deform the pipe while cutting. This will drastically reduce the heating efficiency of the unit.

Step 2: Remove burrs

Burrs can affect the air-tight seal of refrigerant piping connection. They must be completely removed.

1. Hold the pipe at a downward angle to prevent burrs from falling into the pipe.
2. Using a reamer or deburring tool, remove all burrs from the cut section of the pipe.

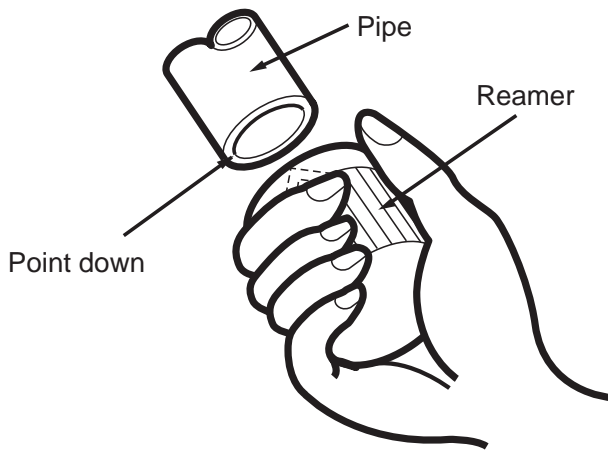

Fig. 5.2

Step 3: Flare pipe ends

Proper flaring is essential to achieve an airtight seal.

1. After removing burrs from cut pipe, seal the ends with PVC tape to prevent foreign materials from entering the pipe.
2. Sheath the pipe with insulating material.
3. Place flare nuts on both ends of pipe. Make sure they are facing in the right direction, because you can't put them on or change their direction after flaring. See Fig. 5.3.

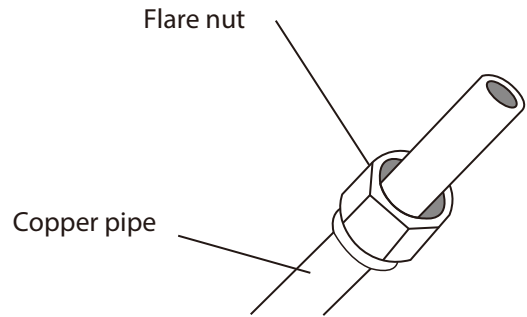

Fig. 5.3

4. Remove PVC tape from ends of pipe when ready to perform flaring work.
5. Clamp flare form on the end of the pipe. The end of the pipe must extend beyond the edge of the flare form in accordance with the dimensions shown in the table below.

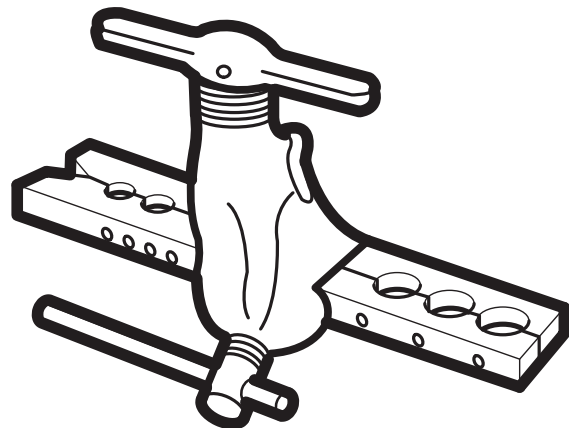

Fig. 5.4

PIPING EXTENSION BEYOND FLARE FORM

Outer Diameter of Pipe (mm)	A (mm)	
	Min.	Max.
Ø 6.35 (Ø 0.25")	0.7 (0.0275")	1.3 (0.05")
Ø 9.52 (Ø 0.375")	1.0 (0.04")	1.6 (0.063")
Ø 12.7 (Ø 0.5")	1.0 (0.04")	1.8 (0.07")
Ø 16 (Ø 0.63")	2.0 (0.078")	2.2 (0.086")

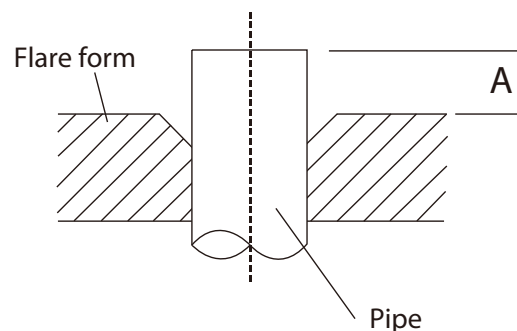

Fig. 5.5

6. Place flaring tool onto the form.
7. Turn the handle of the flaring tool clockwise until the pipe is fully flared.
8. Remove the flaring tool and flare form, then inspect the end of the pipe for cracks and even flaring.

Step 4: Connect pipes

When connecting refrigerant pipes, be careful not to use excessive torque or to deform the piping in any way. You should first connect the low-pressure pipe, then the high-pressure pipe.

MINIMUM BEND RADIUS

When bending connective refrigerant piping, the minimum bending radius is 10cm. See Fig.5.6

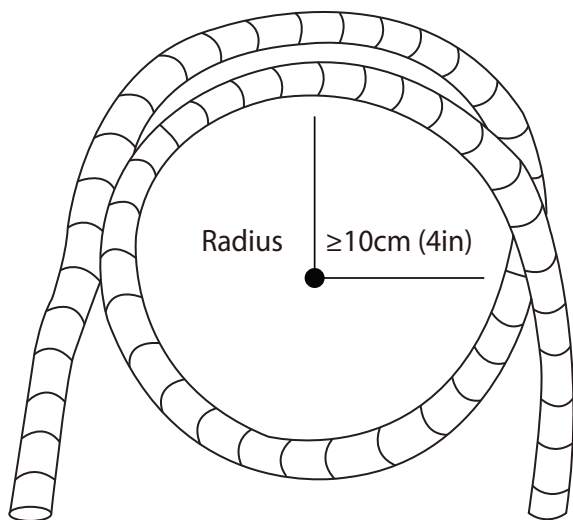

Fig. 5.6

Instructions for Connecting Piping to Indoor Unit

1. Align the center of the two pipes that you will connect. See Fig. 5.7 .

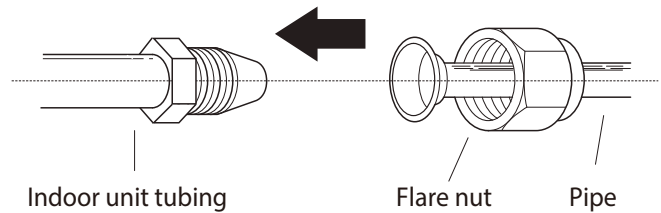

Fig. 5.7

2. Tighten the flare nut as tightly as possible by hand.
3. Using a spanner, grip the nut on the unit tubing.
4. While firmly gripping the nut on the unit tubing, use a torque wrench to tighten the flare nut according to the torque values in the Torque Requirements table below. Loosen the flaring nut slightly, then tighten again.

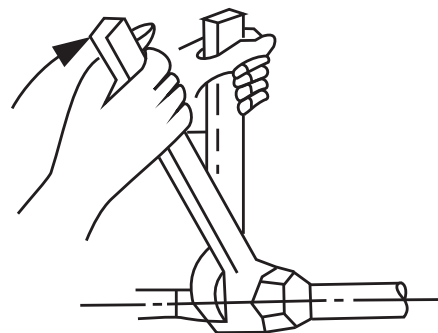

Fig. 5.8

TORQUE REQUIREMENTS

Outer Diameter of Pipe (mm)	Tightening Torque (N·cm)	Add. Tightening Torque (N·m)
Ø 6.35 (Ø 0.25")	1,500 (11lb · ft)	1,600 (11.8lb · ft)
Ø 9.52 (Ø 0.375")	2,500 (18.4lb · ft)	2,600 (19.18lb · ft)
Ø 12.7 (Ø 0.5")	3,500 (25.8lb·ft)	3,600 (26.55lb·ft)
Ø 16 (Ø 0.63")	4,500 (33.19lb·ft)	4,700 (34.67lb·ft)

! DO NOT USE EXCESSIVE TORQUE

Excessive force can break the nut or damage the refrigerant piping. You must not exceed torque requirements shown in the table above.

Instructions for Connecting Piping to Outdoor Unit

1. Unscrew the cover from the packed valve on the side of the outdoor unit. (See Fig. 5.9)

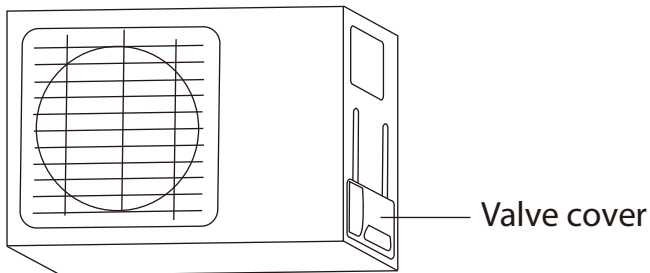

Fig. 5.9

2. Remove protective caps from ends of valves.
3. Align flared pipe end with each valve, and tighten the flare nut as tightly as possible by hand.
4. Using a spanner, grip the body of the valve. Do not grip the nut that seals the service valve. (See Fig. 5.10)

! USE SPANNER TO GRIP MAIN BODY OF VALVE

Torque from tightening the flare nut can snap off other parts of valve.

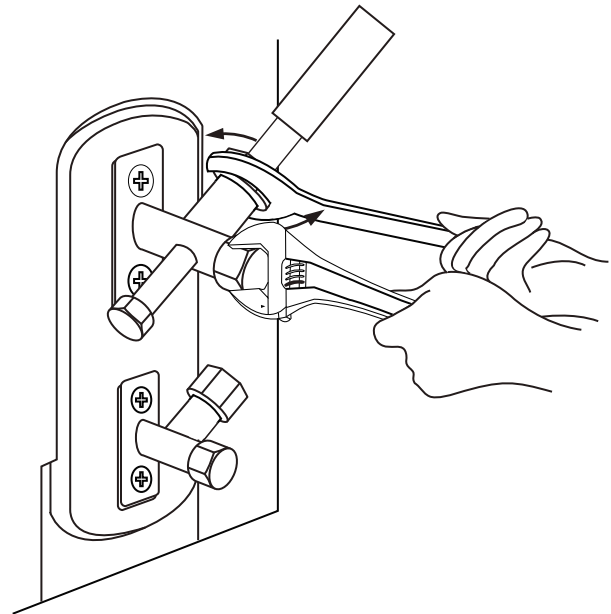
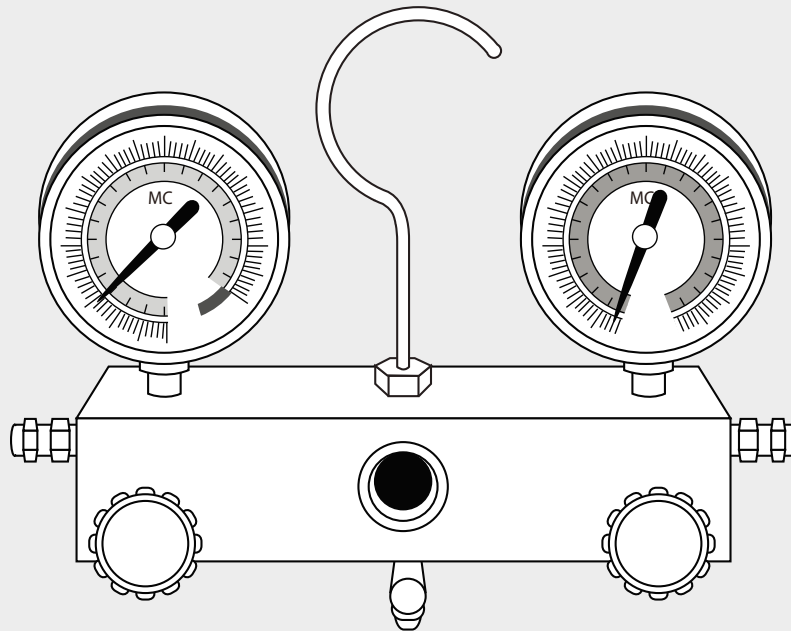

Fig. 5.10

5. While firmly gripping the body of the valve, use a torque wrench to tighten the flare nut according to the correct torque values.
6. Loosen the flaring nut slightly, then tighten again.
7. Repeat Steps 3 to 6 for the remaining pipe.



Preparations and Precautions

Air and foreign matter in the refrigerant circuit can cause abnormal rises in pressure, which can damage the air conditioner, reduce its efficiency, and cause injury. Use a vacuum pump and manifold gauge to evacuate the refrigerant circuit, removing any non-condensable gas and moisture from the system.

Evacuation should be performed upon initial installation and when unit is relocated.

BEFORE PERFORMING EVACUATION

- ☑ Check to make sure that both high-pressure and low-pressure pipes between the indoor and outdoor units are connected properly in accordance with the Refrigerant Piping Connection section of this manual.
- ☑ Check to make sure all wiring is connected properly.

Evacuation Instructions

Before using the manifold gauge and vacuum pump, read their operation manuals to familiarize yourself with how to use them properly.

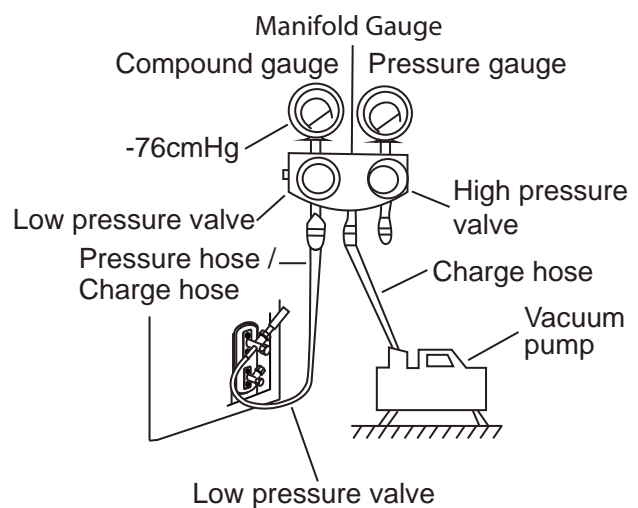

Fig. 6.1

1. Connect the charge hose of the manifold gauge to service port on the outdoor unit's low pressure valve.
2. Connect another charge hose from the manifold gauge to the vacuum pump.

3. Open the Low Pressure side of the manifold gauge. Keep the High Pressure side closed.
4. Turn on the vacuum pump to evacuate the system.
5. Run the vacuum for at least 15 minutes, or until the Compound Meter reads -76cmHG (-10⁵ Pa).
6. Close the Low Pressure side of the manifold gauge, and turn off the vacuum pump.
7. Wait for 5 minutes, then check that there has been no change in system pressure.
8. If there is a change in system pressure, refer to Gas Leak Check section for information on how to check for leaks. If there is no change in system pressure, unscrew the cap from the packed valve (high pressure valve).
9. Insert hexagonal wrench into the packed valve (high pressure valve) and open the valve by turning the wrench in a 1/4 counterclockwise turn. Listen for gas to exit the system, then close the valve after 5 seconds.
10. Watch the Pressure Gauge for one minute to make sure that there is no change in pressure. The Pressure Gauge should read slightly higher than atmospheric pressure.

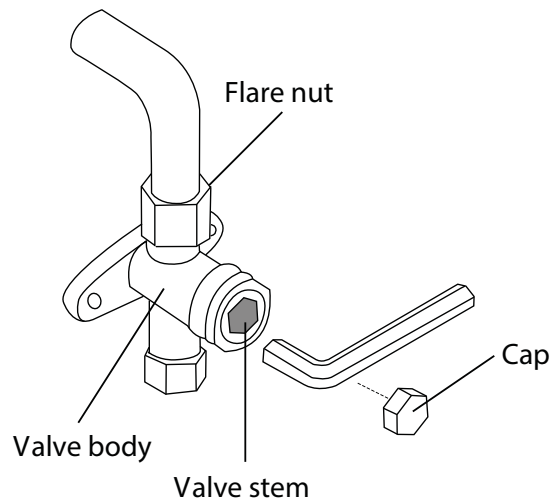

Fig. 6.2

11. Remove the charge hose from the service port.
12. Using hexagonal wrench, fully open both the high pressure and low pressure valves.
13. Tighten valve caps on all three valves (service port, high pressure, low pressure) by hand. You may tighten it further using a torque wrench if needed.

! OPEN VALVE STEMS GENTLY

When opening valve stems, turn the hexagonal wrench until it hits against the stopper. Do not try to force the valve to open further.

Note on Adding Refrigerant

Some systems require additional charging depending on pipe lengths. The standard pipe length varies according to local regulations. For example, in North America, the standard pipe length is 7.5m (25'). In other areas, the standard pipe length is 5m (16'). The additional refrigerant to be charged can be calculated using the following formula:

ADDITIONAL REFRIGERANT PER PIPE LENGTH

Connective Pipe Length (m)	Air Purging Method	Additional Refrigerant	
≤ Standard pipe length	Vacuum Pump	N/A	
> Standard pipe length	Vacuum Pump	Liquid Side: Ø 6.35 (ø 0.25") R32: (Pipe length – standard length) x 12g/m (Pipe length – standard length) x 0.13oz/ft R290: (Pipe length – standard length) x 10g/m (Pipe length – standard length) x 0.10oz/ft	Liquid Side: Ø 9.52 (ø 0.375") R32: (Pipe length – standard length) x 24g/m (Pipe length – standard length) x 0.26oz/ft R290: (Pipe length – standard length) x 18g/m (Pipe length – standard length) x 0.19oz/ft

For R290 refrigerant unit, the total amount of refrigerant to be charged is no more than: 387g(≤9000Btu/h), 447g(>9000Btu/h and ≤12000Btu/h), 547g(>12000Btu/h and ≤18000Btu/h), 632g(>18000Btu/h and ≤24000Btu/h),

! CAUTION DO NOT mix refrigerant types.

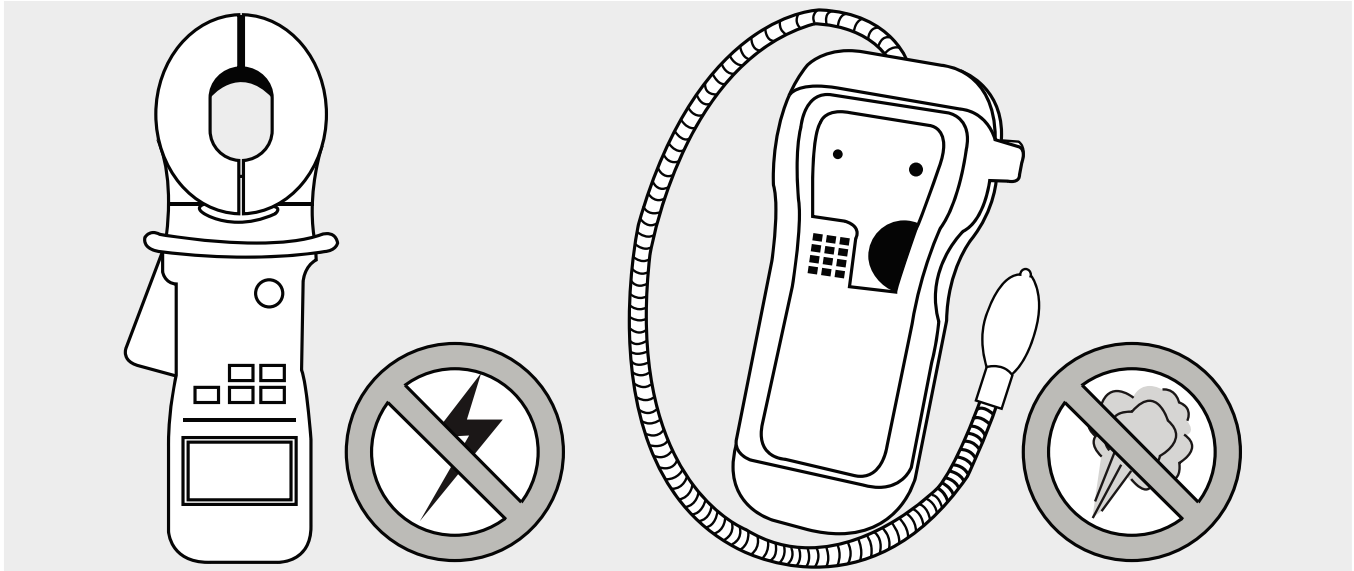

Electrical Safety Checks

After installation, confirm that all electrical wiring is installed in accordance with local and national regulations, and according to the Installation Manual.

BEFORE TEST RUN

Check Grounding Work

Measure grounding resistance by visual detection and with grounding resistance tester. Grounding resistance must be less than 4Ω .

Note: This may not be required for some locations in the US.

DURING TEST RUN

Check for Electrical Leakage

During the Test Run, use an electroprobe and multimeter to perform a comprehensive electrical leakage test.

If electrical leakage is detected, turn off the unit immediately and call a licensed electrician to find and resolve the cause of the leakage.

Note: This may not be required for some locations in the US.

WARNING – RISK OF ELECTRIC SHOCK

ALL WIRING MUST COMPLY WITH LOCAL AND NATIONAL ELECTRICAL CODES, AND MUST BE INSTALLED BY A LICENSED ELECTRICIAN.

Gas Leak Checks

There are two different methods to check for gas leaks.

Soap and Water Method

Using a soft brush, apply soapy water or liquid detergent to all pipe connection points on the indoor unit and outdoor unit. The presence of bubbles indicates a leak.

Leak Detector Method

If using leak detector, refer to the device's operation manual for proper usage instructions.

AFTER PERFORMING GAS LEAK CHECKS

After confirming that the all pipe connection points DO NOT leak, replace the valve cover on the outside unit.

Test Run

9

Before Test Run

Only perform test run after you have completed the following steps:

- Electrical Safety Checks – Confirm that the unit's electrical system is safe and operating properly
- Gas Leak Checks – Check all flare nut connections and confirm that the system is not leaking
- Confirm that gas and liquid (high and low pressure) valves are fully open

Test Run Instructions

You should perform the Test Run for at least 30 minutes.

1. Connect power to the unit.
2. Press the ON/OFF button on the remote controller to turn it on.
3. Press the MODE button to scroll through the following functions, one at a time:
 - COOL – Select lowest possible temperature
 - HEAT – Select highest possible temperature
4. Let each function run for 5 minutes, and perform the following checks:

List of Checks to Perform	PASS/FAIL	
No electrical leakage		
Unit is properly grounded		
All electrical terminals properly covered		
Indoor and outdoor units are solidly installed		
All pipe connection points do not leak	Outdoor (2):	Indoor (2):
Water drains properly from drain hose		
All piping is properly insulated		
Unit performs COOL function properly		
Unit performs HEAT function properly		
Indoor unit louvers rotate properly		
Indoor unit responds to remote controller		

DOUBLE-CHECK PIPE CONNECTIONS

During operation, the pressure of the refrigerant circuit will increase. This may reveal leaks that were not present during your initial leak check. Take time during the Test Run to double-check that all refrigerant pipe connection points do not have leaks. Refer to Gas Leak Check section for instructions.

5. After the Test Run is successfully completed, and you confirm that all checks points in List of Checks to Perform have PASSED, do the following:
 - a. Using remote control, return unit to normal operating temperature.
 - b. Using insulation tape, wrap the indoor refrigerant pipe connections that you left uncovered during the indoor unit installation process.

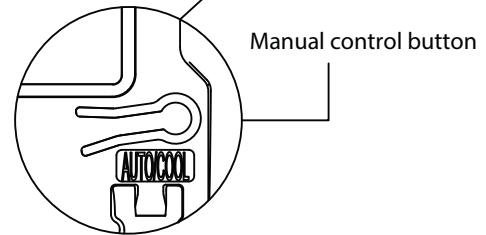
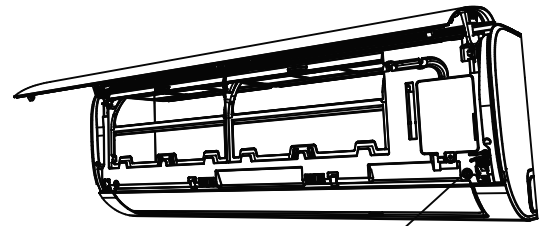

Fig. 8.1

IF AMBIENT TEMPERATURE IS BELOW 17°C (63°F)

You can't use the remote controller to turn on the COOL function when the ambient temperature is below 17°C. In this instance, you can use the MANUAL CONTROL button to test the COOL function.

1. Lift the front panel of the indoor unit, and raise it until it clicks in place.
2. The MANUAL CONTROL button is located on the right-hand side of the unit. Press it 2 times to select the COOL function. See Fig.8.1
3. Perform Test Run as normal.

European Disposal Guidelines

10

This appliance contains refrigerant and other potentially hazardous materials. When disposing of this appliance, the law requires special collection and treatment. Do not dispose of this product as household waste or unsorted municipal waste.

When disposing of this appliance, you have the following options:

- Dispose of the appliance at designated municipal electronic waste collection facility.
- When buying a new appliance, the retailer will take back the old appliance free of charge.
- The manufacturer will take back the old appliance free of charge.
- Sell the appliance to certified scrap metal dealers.

Special notice

Disposing of this appliance in the forest or other natural surroundings endangers your health and is bad for the environment. Hazardous substances may leak into the ground water and enter the food chain.

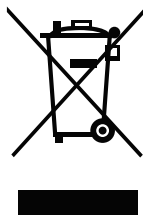

1. Checks to the area

Prior to beginning work on systems containing flammable refrigerants, safety checks are necessary to ensure that the risk of ignition is minimised. For repair to the refrigerating system, the following precautions shall be complied with prior to conducting work on the system.

2. Work procedure

Works shall be undertaken under a controlled procedure so as to minimise the risk of a flammable gas or vapour being present while the work is being performed.

3. General work area

All maintenance staff and others working in the local area shall be instructed on the nature of work being carried out. Work in confined spaces shall be avoided. The area around the work space shall be sectioned off. Ensure that the conditions within the area have been made safe by control of flammable material.

4. Checking for presence of refrigerant

The area shall be checked with an appropriate refrigerant detector prior to and during work, to ensure the technician is aware of potentially flammable atmospheres. Ensure that the leak detection equipment being used is suitable for use with flammable refrigerants, i.e. no sparking, adequately sealed or intrinsically safe.

5. Presence of fire extinguisher

If any hot work is to be conducted on the refrigeration equipment or any associated parts, appropriate fire extinguishing equipment shall be available to hand. Have a dry power or CO₂ fire extinguisher adjacent to the charging area.

6. No ignition sources

No person carrying out work in relation to a refrigeration system which involves exposing any pipe work that contains or has contained flammable refrigerant shall use any sources of ignition in such a manner that it may lead to the risk of fire or explosion. All possible ignition sources, including cigarette smoking, should be kept sufficiently far away from the site of installation, repairing, removing and disposal, during which flammable refrigerant can possibly be released to the surrounding space. Prior to work taking place, the area around the equipment is to be surveyed to make sure that there are no flammable hazards or ignition risks. **NO SMOKING** signs shall be displayed.

7. Ventilated area

Ensure that the area is in the open or that it is adequately ventilated before breaking into the system or conducting any hot work. A degree of ventilation shall continue during the period that the work is carried out. The ventilation should safely disperse any released refrigerant and preferably expel it externally into the atmosphere.

8. Checks to the refrigeration equipment

Where electrical components are being changed, they shall be fit for the purpose and to the correct specification. At all times the manufacturer's maintenance and service guidelines shall be followed. If in doubt consult the manufacturer's technical department for assistance. The following checks shall be applied to installations using flammable refrigerants:

- the charge size is in accordance with the room size within which the refrigerant containing parts are installed;
- the ventilation machinery and outlets are operating adequately and are not obstructed;
- if an indirect refrigerating circuit is being used, the secondary circuits shall be checked for the presence of refrigerant; marking to the equipment continues to be visible and legible.
- marking and signs that are illegible shall be corrected;
- refrigeration pipe or components are installed in a position where they are unlikely to be exposed to any substance which may corrode refrigerant containing components, unless
- the components are constructed of materials which are inherently resistant to being
- corroded or are suitably protected against being so corroded.

9. Checks to electrical devices

Repair and maintenance to electrical components shall include initial safety checks and component inspection procedures. If a fault exists that could compromise safety, then no electrical supply shall be connected to the circuit until it is satisfactorily dealt with. If the fault cannot be corrected immediately but it is necessary to continue operation, and adequate temporary solution shall be used. This shall be reported to the owner of the equipment so all parties are advised.

Initial safety checks shall include:

- that capacitors are discharged: this shall be done in a safe manner to avoid possibility of sparking
- that there no live electrical components and wiring are exposed while charging, recovering or purging the system;
- that there is continuity of earth bonding.

10. Repairs to sealed components

10.1 During repairs to sealed components, all electrical supplies shall be disconnected from the equipment being worked upon prior to any removal of sealed covers, etc. If it is absolutely necessary to have an electrical supply to equipment during servicing, then a permanently operating form of leak detection shall be located at the most critical point to warn of a potentially hazardous situation.

10.2 Particular attention shall be paid to the following to ensure that by working on electrical components, the casing is not altered in such a way that the level of protection is affected. This shall include damage to cables, excessive number of connections, terminals not made to original specification, damage to seals, incorrect fitting of glands, etc.

- Ensure that apparatus is mounted securely.
- Ensure that seals or sealing materials have not degraded such that they no longer serve the purpose of preventing the ingress of flammable atmospheres. Replacement parts shall be in accordance with the manufacturer s specifications.

NOTE: The use of silicon sealant may inhibit the effectiveness of some types of leak detection equipment. Intrinsically safe components do not have to be isolated prior to working on them.

11. Repair to intrinsically safe components

Do not apply any permanent inductive or capacitance loads to the circuit without ensuring that this will not exceed the permissible voltage and current permitted for the equipment in use. Intrinsically safe components are the only types that can be worked on while live in the presence of a flammable atmosphere. The test apparatus shall be at the correct rating.

Replace components only with parts specified by the manufacturer. Other parts may result in the ignition of refrigerant in the atmosphere from a leak.

12. Cabling

Check that cabling will not be subject to wear, corrosion, excessive pressure, vibration, sharp edges or any other adverse environmental effects. The check shall also take into account the effects of aging or continual vibration from sources such as compressors or fans.

13. Detection of flammable refrigerants

Under no circumstances shall potential sources of ignition be used in the searching for or detection of refrigerant leaks. A halide torch (or any other detector using a naked flame) shall not be used.

14. Leak detection methods

The following leak detection methods are deemed acceptable for systems containing flammable refrigerants. Electronic leak detectors shall be used to detect flammable refrigerants, but the sensitivity may not be adequate, or may need re-calibration. (Detection equipment shall be calibrated in a refrigerant-free area.) Ensure that the detector is not a potential source of ignition and is suitable for the refrigerant. Leak detection equipment shall be set at a percentage of the LFL of the refrigerant and shall be calibrated to the refrigerant employed and the appropriate percentage of gas (25% maximum) is confirmed. Leak detection fluids are suitable for use with most refrigerants but the use of detergents containing chlorine shall be avoided as the chlorine may react with the refrigerant and corrode the copper pipe-work.

If a leak is suspected, all naked flames shall be removed or extinguished. If a leakage of refrigerant is found which requires brazing, all of the refrigerant shall be recovered from the system, or isolated (by means of shut off valves) in a part of the system remote from the leak. Oxygen free nitrogen (OFN) shall then be purged through the system both before and during the brazing process.

15. Removal and evacuation

When breaking into the refrigerant circuit to make repairs or for any other purpose conventional procedures shall be used. However, it is important that best practice is followed since flammability is a consideration. The following procedure shall be adhered to:

- remove refrigerant;
- purge the circuit with inert gas;
- evacuate;
- purge again with inert gas;
- open the circuit by cutting or brazing.

The refrigerant charge shall be recovered into the correct recovery cylinders. The system shall be flushed with OFN to render the unit safe. This process may need to be repeated several times. Compressed air or oxygen shall not be used for this task.

Flushing shall be achieved by breaking the vacuum in the system with OFN and continuing to fill until the working pressure is achieved, then venting to atmosphere, and finally pulling down to a vacuum. This process shall be repeated until no refrigerant is within the system.

When the final OFN charge is used, the system shall be vented down to atmospheric pressure to enable work to take place. This operation is absolutely vital if brazing operations on the pipe-work are to take place.

Ensure that the outlet for the vacuum pump is not closed to any ignition sources and there is ventilation available.

16. Charging procedures

In addition to conventional charging procedures, the following requirements shall be followed:

- Ensure that contamination of different refrigerants does not occur when using charging equipment. Hoses or lines shall be as short as possible to minimize the amount of refrigerant contained in them.
- Cylinders shall be kept upright.
- Ensure that the refrigeration system is earthed prior to charging the system with refrigerant.
- Label the system when charging is complete (if not already).
- Extreme care shall be taken not to overfill the refrigeration system.
- Prior to recharging the system it shall be pressure tested with OFN. The system shall be leak tested on completion of charging but prior to commissioning. A follow up leak test shall be carried out prior to leaving the site.

17. Decommissioning

Before carrying out this procedure, it is essential that the technician is completely familiar with the equipment and all its detail. It is recommended good practice that all refrigerants are recovered safely. Prior to the task being carried out, an oil and refrigerant sample shall be taken.

In case analysis is required prior to re-use of reclaimed refrigerant. It is essential that electrical power is available before the task is commenced.

- a) Become familiar with the equipment and its operation.
- b) Isolate system electrically
- c) Before attempting the procedure ensure that:
 - mechanical handling equipment is available, if required, for handling refrigerant cylinders;
 - all personal protective equipment is available and being used correctly;
 - the recovery process is supervised at all times by a competent person;
 - recovery equipment and cylinders conform to the appropriate standards.
- d) Pump down refrigerant system, if possible.
- e) If a vacuum is not possible, make a manifold so that refrigerant can be removed from various parts of the system.
- f) Make sure that cylinder is situated on the scales before recovery takes place.
- g) Start the recovery machine and operate in accordance with manufacturer's instructions.
- h) Do not overfill cylinders. (No more than 80% volume liquid charge).
- i) Do not exceed the maximum working pressure of the cylinder, even temporarily.
- j) When the cylinders have been filled correctly and the process completed, make sure that the cylinders and the equipment are removed from site promptly and all isolation valves on the equipment are closed off.
- k) Recovered refrigerant shall not be charged into another refrigeration system unless it has been cleaned and checked.

18. Labelling

Equipment shall be labelled stating that it has been de-commissioned and emptied of refrigerant. The label shall be dated and signed. Ensure that there are labels on the equipment stating the equipment contains flammable refrigerant.

19. Recovery

- When removing refrigerant from a system, either for service or decommissioning, it is recommended good practice that all refrigerants are removed safely.
- When transferring refrigerant into cylinders, ensure that only appropriate refrigerant recovery cylinders are employed. Ensure that the correct numbers of cylinders for holding the total system charge are available. All cylinders to be used are designated for the recovered refrigerant and labelled for that refrigerant (i.e special cylinders for the recovery of refrigerant). Cylinders shall be complete with pressure relief valve and associated shut-off valves in good working order.
- Empty recovery cylinders are evacuated and, if possible, cooled before recovery occurs.
- The recovery equipment shall be in good working order with a set of instructions concerning the equipment that is at hand and shall be suitable for the recovery of flammable refrigerants. In addition, a set of calibrated weighing scales shall be available and in good working order.
- Hoses shall be complete with leak-free disconnect couplings and in good condition. Before using the recovery machine, check that it is in satisfactory working order, has been properly maintained and that any associated electrical components are sealed to prevent ignition in the event of a refrigerant release. Consult manufacturer if in doubt.
- The recovered refrigerant shall be returned to the refrigerant supplier in the correct recovery cylinder, and the relevant Waste Transfer Note arranged. Do not mix refrigerants in recovery units and especially not in cylinders.
- If compressors or compressor oils are to be removed, ensure that they have been evacuated to an acceptable level to make certain that flammable refrigerant does not remain within the lubricant. The evacuation process shall be carried out prior to retraining the compressor to the suppliers. Only electric heating to the compressor body shall be employed to accelerate this process. When oil is drained from a system, it shall be carried out safely.

20. Transportation, marking and storage for units

1. Transport of equipment containing flammable refrigerants
Compliance with the transport regulations
2. Marking of equipment using signs
Compliance with local regulations
3. Disposal of equipment using flammable refrigerants
Compliance with national regulations
4. Storage of equipment/appliances
The storage of equipment should be in accordance with the manufacturer's instructions.
5. Storage of packed (unsold) equipment
Storage package protection should be constructed such that mechanical damage to the equipment inside the package will not cause a leak of the refrigerant charge.
The maximum number of pieces of equipment permitted to be stored together will be determined by local regulations.



CLIVET SPA

Via Camp Lonc 25, Z.I. Villapaiera - 32032 Feltre (BL) - Italy
Tel. + 39 0439 3131 - Fax + 39 0439 313300 - info@clivet.it

CLIVET GROUP UK Limited

4 Kingdom Close, Segensworth East - Fareham, Hampshire - PO15 5TJ - United Kingdom
Tel. + 44 (0) 1489 572238 - Fax + 44 (0) 1489 573033 - enquiries@clivetgroup.co.uk

CLIVET GROUP UK Limited (Service Department)

Units F5&F6 Railway Triangle Ind Est, Walton Road - Portsmouth, Hampshire - PO6 1TG - United Kingdom
Tel. +44 (0) 2392 381235 - Fax. +44 (0) 2392 381243 - service@clivetgroup.co.uk

CLIVET ESPAÑA S.A.U.

C/ Bac de Roda, 36 - 08019 Barcelona - España
Tel: +34 93 8606248 - Fax +34 93 8855392 - info@clivet.es

Av.Manoteras Nº 38, Oficina C303 - 28050 Madrid - España
Tel. +34 91 6658280 - Fax +34 91 6657806 - info@clivet.es

CLIVET GmbH (Hydronic and Applied Division)

Hummelsbütteler Steindamm 84, 22851 Norderstedt - Germany
Tel. + 49 (0) 40 32 59 57-0 - Fax + 49 (0) 40 32 59 57-194 - info.de@clivet.com

CLIVET GmbH (VRF, Residential and Lightcom Division)

Eisenstrasse 9c, 65428 Rüsselsheim/Frankfurt - Germany
Tel. + 49 (0) 6142 83594-0 - Fax + 49 (0) 6142 83594-20 - vrf.de@clivet.com

CLIVET RUSSIA

Elektrozavodskaya st. 24, office 509 - 107023, Moscow, Russia
Tel. + 74956462009 - Fax + 74956462009 - info.ru@clivet.com

CLIVET MIDEAST FZCO

Dubai Silicon Oasis (DSO), High Bay Complex, Office N. 20, PO BOX 342009, Dubai, UAE
Tel. + 9714 3208499 - Fax + 9714 3208216 - info@clivet.ae

CLIVET AIRCONDITIONING SYSTEMS PRIVATE LIMITED

4BA, Gundecha Onclave, Kherani Road - Sakinaka, Andheri (East) - Mumbai 400 072 - India
Tel. +91 22 6193 7000 - Fax +91 22 6193 7001 - info.in@clivet.com

The data contained in this manual is not binding and may be changed by the manufacturer without prior notice.
Reproduction, even in part, is FORBIDDEN © Copyright - CLIVET S.p.A. - Feltre (BL) - Italia

A Group Company of



www.clivet.com
www.clivetlive.com



OWNER'S MANUAL

Cristallo

Cristallo-SM

SPLIT-TYPE ROOM AIR CONDITIONER



Series IM1-XY 27M-70M

IMPORTANT NOTE:

Read this manual carefully before installing or operating your new air conditioning unit. For installation information, refer to the manual of the outdoor unit.

Make sure to save this manual for future reference.



Change living home

Table of Contents

Owner's Manual

0 Safety Precautions.....04

1 Unit Specifications and Features.....06



2 Manual Operation
(Without Remote).....11

3 Care and Maintenance.....12

4 Troubleshooting.....14

5 European Disposal Guidelines.....18

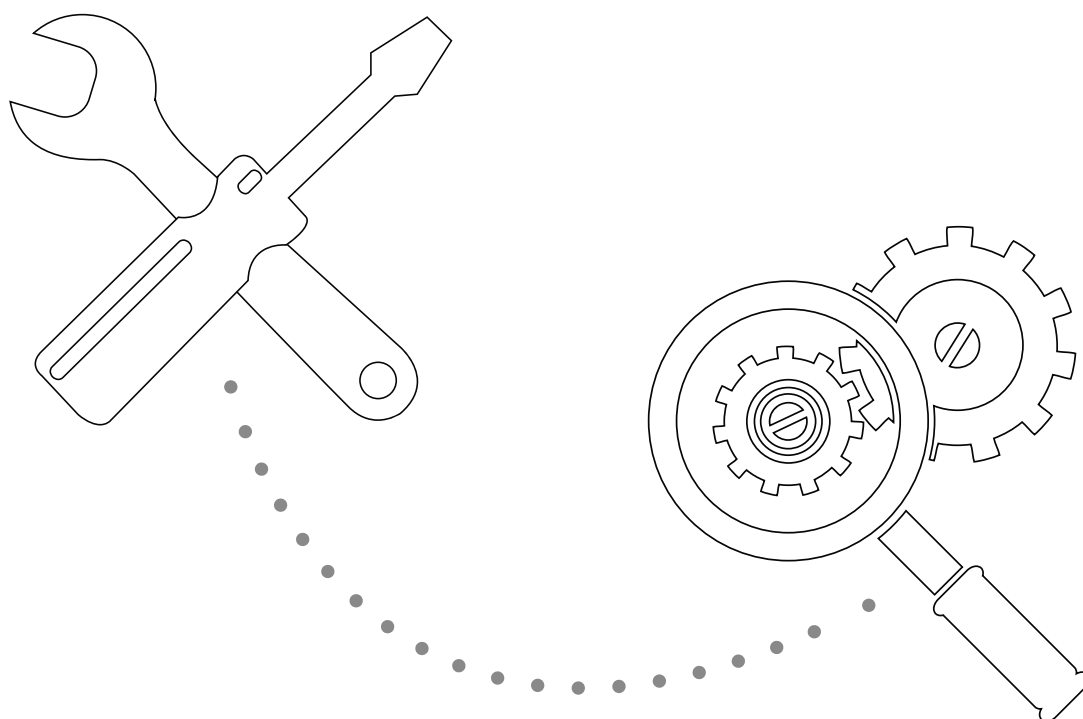

Caution: **Risk of fire/
flammable materials**
(only for refrigerant R32-R290)

WARNING: Servicing shall only be performed as recommended by the equipment manufacturer. Maintenance and repair requiring the assistance of other skilled personnel shall be carried out under the supervision of the person competent in the use of flammable refrigerants. For more details ,please refer to the “Information on servicing” on “INSTALLATION MANUAL .”

Safety Precautions

Read Safety Precautions Before Installation

Incorrect installation due to ignoring instructions can cause serious damage or injury. The seriousness of potential damage or injuries is classified as either a **WARNING** or **CAUTION**.



WARNING

This symbol indicates that ignoring instructions may cause death or serious injury.



CAUTION

This symbol indicates that ignoring instructions may cause moderate injury to your person, or damage to your appliance or other property.

WARNING

This appliance can be used by children aged from 8 years and above and persons with reduced physical, sensory or mental capabilities or lack of experience and knowledge if they have been given supervision or instruction concerning use of the appliance in a safe way and understand the hazards involved. Children shall not play with the appliance. Cleaning and user maintenance shall not be made by children without supervision.

INSTALLATION WARNINGS

- Ask an authorized dealer to install this air conditioner. Inappropriate installation may cause water leakage, electric shock, or fire.
- All repairs, maintenance and relocation of this unit must be performed by an authorized service technician. Inappropriate repairs can lead to serious injury or product failure.

WARNINGS FOR PRODUCT USE

- If an abnormal situation arises (like a burning smell), immediately turn off the unit and pull the power plug. Call your dealer for instructions to avoid electric shock, fire or injury.
- Do not insert fingers, rods or other objects into the air inlet or outlet. This may cause injury, since the fan may be rotating at high speeds.
- Do not use flammable sprays such as hair spray, lacquer or paint near the unit. This may cause fire or combustion.
- Do not operate the air conditioner in places near or around combustible gases. Emitted gas may collect around the unit and cause explosion.
- Do not operate the air conditioner in a wet room (e.g., bathroom or laundry room). This can cause electrical shock and cause the product to deteriorate.
- Do not expose your body directly to cool air for a prolonged period of time.

ELECTRICAL WARNINGS

- Only use the specified power cord. If the power cord is damaged, it must be replaced by the manufacturer or certified service agent.
- Keep power plug clean. Remove any dust or grime that accumulates on or around the plug. Dirty plugs can cause fire or electric shock.
- Do not pull power cord to unplug unit. Hold the plug firmly and pull it from the outlet. Pulling directly on the cord can damage it, which can lead to fire or electric shock.
- Do not use an extension cord, manually extend the power cord, or connect other appliances to the same outlet as the air conditioner. Poor electrical connections, poor insulation, and insufficient voltage can cause fire.





CLEANING AND MAINTENANCE WARNINGS

- Turn off the device and pull the plug before cleaning. Failure to do so can cause electrical shock.
- Do not clean the air conditioner with excessive amounts of water.
- Do not clean the air conditioner with combustible cleaning agents. Combustible cleaning agents can cause fire or deformation.

CAUTION

- If the air conditioner is used together with burners or other heating devices, thoroughly ventilate the room to avoid oxygen deficiency.
- Turn off the air conditioner and unplug the unit if you are not going to use it for a long time.
- Turn off and unplug the unit during storms.
- Make sure that water condensation can drain unhindered from the unit.
- Do not operate the air conditioner with wet hands. This may cause electric shock.
- Do not use device for any other purpose than its intended use.
- Do not climb onto or place objects on top of the outdoor unit.
- Do not allow the air conditioner to operate for long periods of time with doors or windows open, or if the humidity is very high.

Explanation of symbols displayed on the indoor unit or outdoor unit:

	WARNING	This symbol shows that this appliance used a flammable refrigerant. If the refrigerant is leaked and exposed to an external ignition source, there is a risk of fire.
	CAUTION	This symbol shows that the operation manual should be read carefully.
	CAUTION	This symbol shows that a service personnel should be handling this equipment with reference to the installation manual.
	CAUTION	
	CAUTION	This symbol shows that information is available such as the operating manual or installation manual.

Unit Specifications and Features

1

Unit Parts

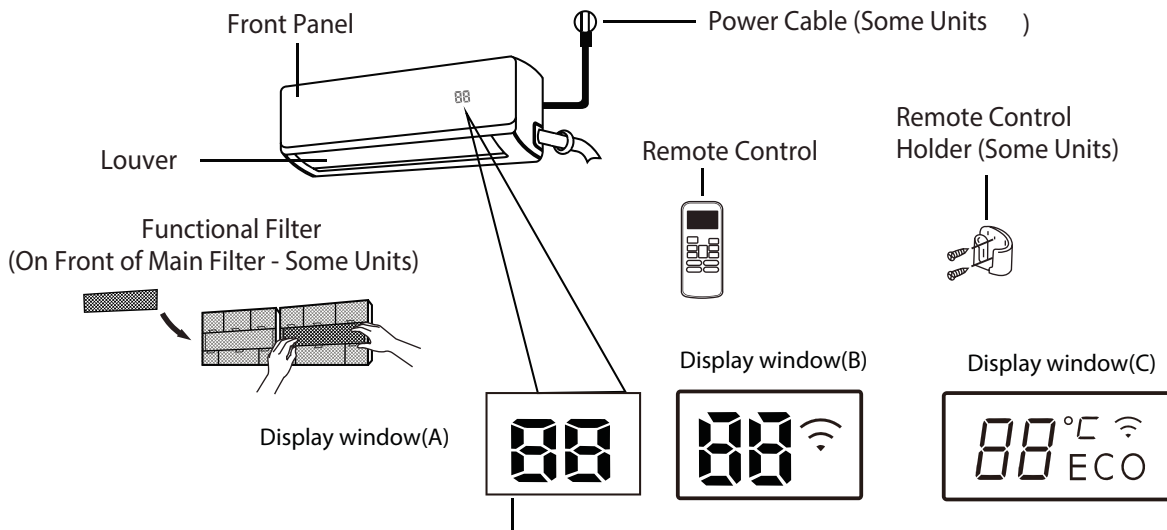

- " **00** " for 3 seconds when:
 - TIMER ON is set
 - FRESH, SWING, TURBO, or SILENCE features are turned on
- " **0F** " for 3 seconds when:
 - TIMER OFF is set
 - FRESH, SWING, TURBO, or SILENCE features are turned off
- " **cF** " when anti-cold air feature is turned on
- " **dF** " when defrosting
- " **SC** " when unit is self-cleaning
- " **FP** " when freeze protection is turned on
- " **88** " When ECO function(some units) is activated, the '88' illuminates gradually one by one as $\text{E} \rightarrow \text{C} \rightarrow \text{O}$ --set temperature-- $\text{E} \dots$ in one second interval.
- " C " when Wireless Control feature is activated(some units)
- " **ECO** " when ECO function is activated(some units)
- " $^{\circ}\text{C}$ " Lights up in different colour according to the operation mode(some units):
 - Under COOL and DRY mode, it displays as cool colour.
 - Under HEAT mode, it displays as warm colour.

Display Code Meanings

In Fan mode, the unit will display the room temperature.
In other modes, the unit will display your temperature setting.

NOTE: A guide on using the infrared remote is not included in this literature package.

Achieving Optimal Performance

Optimal performance for the COOL, HEAT, and DRY modes can be achieved in the following temperature ranges. When your air conditioner is used outside of these ranges, certain safety protection features will activate and cause the unit to perform less than optimally.

Inverter Split Type

	COOL mode	HEAT mode	DRY mode
Room Temperature	17°C - 32°C (63°F - 90°F)	0°C - 30°C (32°F - 86°F)	10°C - 32°C (50°F - 90°F)
Outdoor Temperature	0°C - 50°C (32°F - 122°F)	-15°C - 30°C (5°F - 86°F)	0°C - 50°C (32°F - 122°F)
	-15°C - 50°C (5°F - 122°F) (For models with low temp. cooling systems.)		
	0°C - 60°C (32°F - 140°F) (For special tropical models)		0°C - 60°C (32°F - 140°F) (For special tropical models)

FOR OUTDOOR UNITS WITH AUXILIARY ELECTRIC HEATER
When outside temperature is below 0°C (32°F), we strongly recommend keeping the unit plugged in at all time to ensure smooth ongoing performance.

Fixed-speed Type

	COOL mode	HEAT mode	DRY mode
Room Temperature	17°-32°C (63°-90°F)	0°-30°C (32°-86°F)	10°-32°C (50°-90°F)
Outdoor Temperature	18°-43°C (64°-109°F)	-7°-24°C (19°-75°F)	11°-43°C (52°-109°F)
	-7°-43°C (19°-109°F) (For models with low-temp cooling systems)		18°-43°C (64°-109°F)
	18°-54°C (64°-129°F) (For special tropical models)		18°-54°C (64°-129°F) (For special tropical models)

To further optimize the performance of your unit, do the following:

- Keep doors and windows closed.
- Limit energy usage by using TIMER ON and TIMER OFF functions.
- Do not block air inlets or outlets.
- Regularly inspect and clean air filters.

For a detailed explanation of each function, refer to the Remote Control Manual.

Other Features

- **Auto-Restart**
If the unit loses power, it will automatically restart with the prior settings once power has been restored.
- **Anti-mildew (some units)**
When turning off the unit from COOL, AUTO (COOL), or DRY modes, the air conditioner will continue operate at very low power to dry up condensed water and prevent mildew growth.
- **Wireless Control (some units)**
Wireless control allows you to control your air conditioner using your mobile phone and a wireless connection.
For the USB device access, replacement, maintenance operations must be carried out by professional staff.
- **Louver Angle Memory(some units)**
When turning on your unit, the louver will automatically resume its former angle.
- **(some units)**
The indoor unit will automatically display “EC” when it detects refrigerant leakage.

For a detailed explanation of your unit’s advanced functionality (such as TURBO mode and its self-cleaning functions), refer to the Remote Control Manual.

NOTE ON ILLUSTRATIONS

Illustrations in this manual are for explanatory purposes. The actual shape of your indoor unit may be slightly different. The actual shape shall prevail.

Setting Angle of Air Flow

Setting vertical angle of air flow

While the unit is on, use the SWING/DIRECT button to set the direction (vertical angle) of airflow.

1. Press the SWING/DIRECT button once to activate the louver. Each time you press the button, it will adjust the louver by 6°. Press the button until the direction you prefer is reached.
2. To make the louver swing up and down continuously, press and hold the SWING/DIRECT button for 3 seconds. Press it again to stop the automatic function.

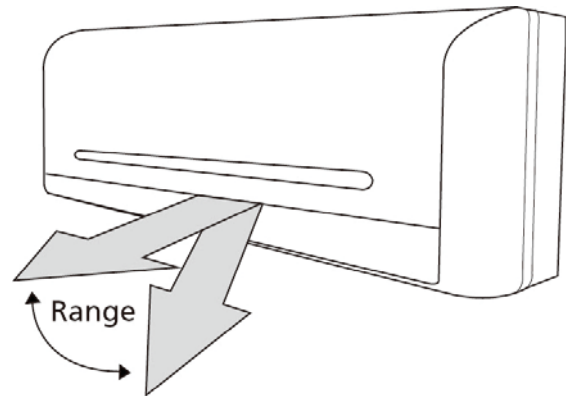

Caution: Do not keep louver at too vertical an angle for long periods of time. This can cause water condensation to drip on your furnishings.

Fig. A

Setting horizontal angle of air flow

The horizontal angle of the airflow must be set manually. Grip the deflector rod (See Fig.B) and manually adjust it to your preferred direction. For some units, the horizontal angle of the airflow can be set by remote control. please refer to the Remote Control Manual.

NOTE ON LOUVER ANGLES

When using COOL or DRY mode, do not set louver at too vertical an angle for long periods of time. This can cause water to condense on the louver blade, which will drop on your floor or furnishings. (See Fig.A)

When using COOL or HEAT mode, setting the louver at too vertical an angle can reduce the performance of the unit due to restricted air flow.

Do not move louver by hand. This will cause the louver to become out of sync. If this occurs, turn off the unit and unplug it for a few seconds, then restart the unit. This will reset the louver.

! CAUTION
Do not put your fingers in or near the blower and suction side of the unit. The high-speed fan inside the unit may cause injury.

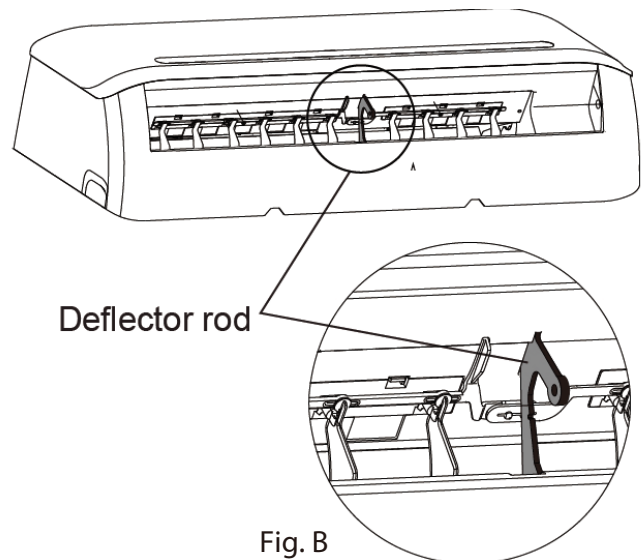

Fig. B

Sleep Operation

The SLEEP function is used to decrease energy use while you sleep (and don't need the same temperature settings to stay comfortable). This function can only be activated via remote control.

Press the SLEEP button when you are ready to go to sleep. When in COOL mode, the unit will increase the temperature by 1°C (2°F) after 1 hour, and will increase an additional 1°C (2°F) after another hour. When in HEAT mode, the unit will decrease the temperature by 1°C (2°F) after 1 hour, and will decrease an additional 1°C (2°F) after another hour.

It will hold the new temperature for 5 hours, then the unit will turn off automatically.

Note: The SLEEP function is not available in FAN or DRY mode.

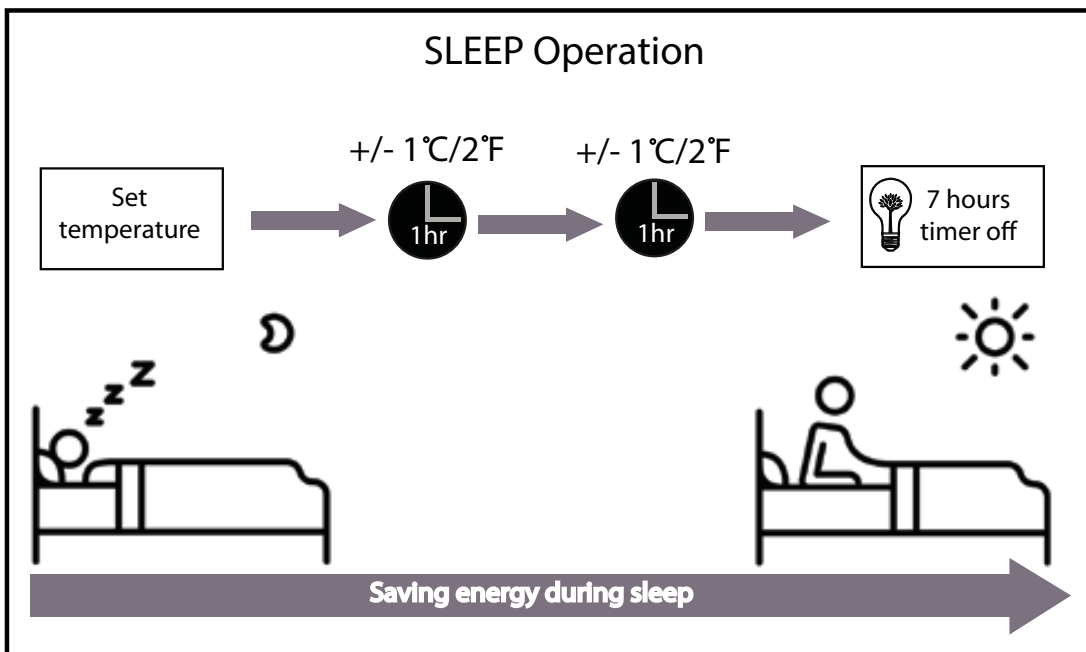

Manual Operation (Without Remote)

2

How to operate your unit without the remote control

In the event that your remote control fails to work, your unit can be operated manually with the **MANUAL CONTROL** button located on the indoor unit. Note that manual operation is not a long-term solution, and that operating the unit with your remote control is strongly recommended.

BEFORE MANUAL OPERATION

Unit must be turned off before manual operation.

To operate your unit manually:

1. Open the front panel of the indoor unit.
2. Locate the **MANUAL CONTROL** button on the right-hand side of the unit.
3. Press the **MANUAL CONTROL** button one time to activate **FORCED AUTO** mode.
4. Press the **MANUAL CONTROL** button again to activate **FORCED COOLING** mode.
5. Press the **MANUAL CONTROL** button a third time to turn the unit off.
6. Close the front panel.

! CAUTION

The manual button is intended for testing purposes and emergency operation only. Please do not use this function unless the remote control is lost and it is absolutely necessary. To restore regular operation, use the remote control to activate the unit.

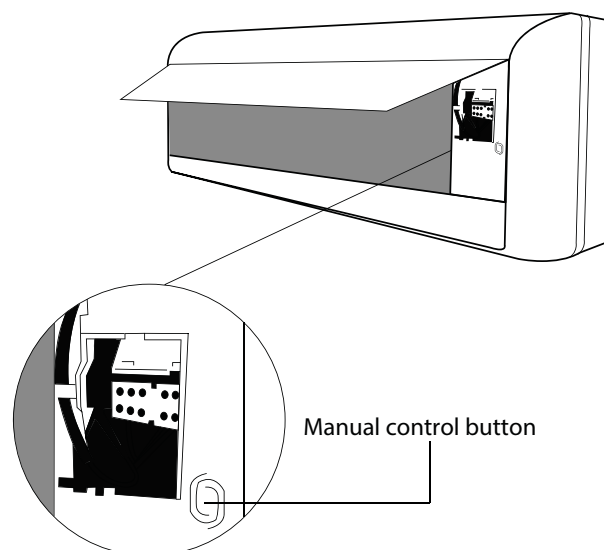

Care and Maintenance

3

Cleaning Your Indoor Unit



BEFORE CLEANING OR MAINTENANCE

ALWAYS TURN OFF YOUR AIR CONDITIONER SYSTEM AND DISCONNECT ITS POWER SUPPLY BEFORE CLEANING OR MAINTENANCE.



CAUTION

Only use a soft, dry cloth to wipe the unit clean. If the unit is especially dirty, you can use a cloth soaked in warm water to wipe it clean.

- Do not use chemicals or chemically treated cloths to clean the unit
- Do not use benzene, paint thinner, polishing powder or other solvents to clean the unit. They can cause the plastic surface to crack or deform.
- Do not use water hotter than 40°C (104°F) to clean the front panel. This can cause the panel to deform or become discolored.

Cleaning Your Air Filter

A clogged air conditioner can reduce the cooling efficiency of your unit, and can also be bad for your health. Make sure to clean the filter once every two weeks.

1. Lift the front panel of the indoor unit.
2. Grip the tab on the end of the filter, lift it up, then pull it towards yourself.
3. Now pull the filter out.
4. If your filter has a small air freshening filter, unclip it from the larger filter. Clean this air freshening filter with a hand-held vacuum.
5. Clean the large air filter with warm, soapy water. Be sure to use a mild detergent.

6. Rinse the filter with fresh water, then shake off excess water.
7. Dry it in a cool, dry place, and refrain from exposing it to direct sunlight.
8. When dry, re-clip the air freshening filter to the larger filter, then slide it back into the indoor unit.
9. Close the front panel of the indoor unit.

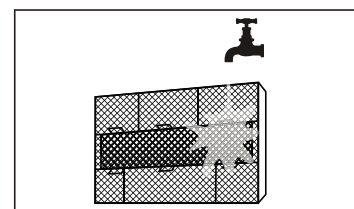
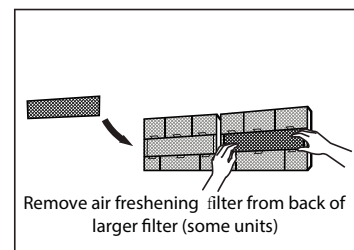
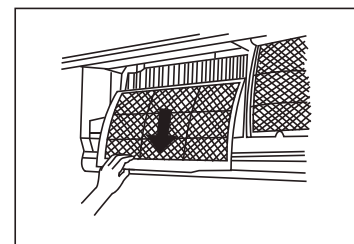
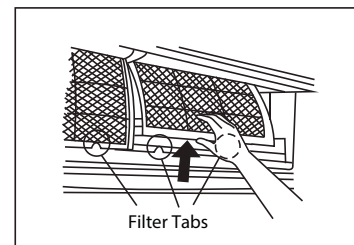

CAUTION

Do not touch air freshening (Plasma) filter for at least 10 minutes after turning off the unit.

! CAUTION

- Before changing the filter or cleaning, turn off the unit and disconnect its power supply.
- When removing filter, do not touch metal parts in the unit. The sharp metal edges can cut you.
- Do not use water to clean the inside of the indoor unit. This can destroy insulation and cause electrical shock.
- Do not expose filter to direct sunlight when drying. This can shrink the filter.

Air Filter Reminders (Optional)

Air Filter Cleaning Reminder

After 240 hours of use, the display window on the indoor unit will flash "CL." This is a reminder to clean your filter. After 15 seconds, the unit will revert to its previous display.

To reset the reminder, press the LED button on your remote control 4 times, or press the MANUAL CONTROL button 3 times. If you don't reset the reminder, the "CL" indicator will flash again when you restart the unit.

Air Filter Replacement Reminder

After 2,880 hours of use, the display window on the indoor unit will flash "nF." This is a reminder to replace your filter. After 15 seconds, the unit will revert to its previous display.

To reset the reminder, press the LED button on your remote control 4 times, or press the MANUAL CONTROL button 3 times. If you don't reset the reminder, the "nF" indicator will flash again when you restart the unit.

! CAUTION

- Any maintenance and cleaning of outdoor unit should be performed by an authorized dealer or a licensed service provider.
- Any unit repairs should be performed by an authorized dealer or a licensed service provider.

Maintenance – Long Periods of Non-Use

If you plan not to use your air conditioner for an extended period of time, do the following:

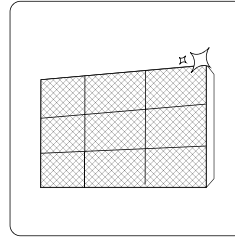

Clean all filters

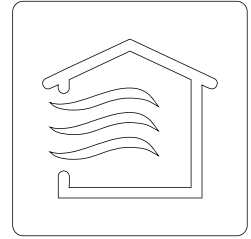

Turn on FAN function until unit dries out completely

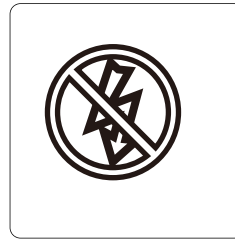

Turn off the unit and disconnect the power

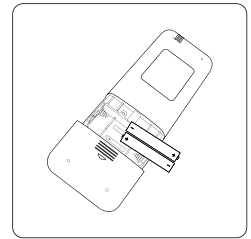

Remove batteries from remote control

Maintenance – Pre-Season Inspection

After long periods of non-use, or before periods of frequent use, do the following:

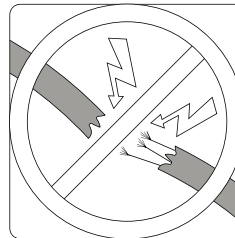

Check for damaged wires

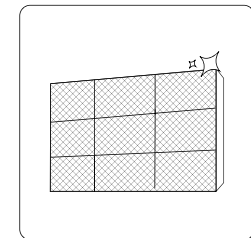

Clean all filters



Check for leaks

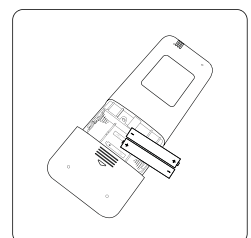

Replace batteries

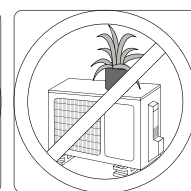
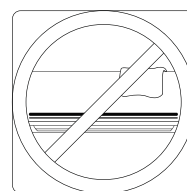

Make sure nothing is blocking all air inlets and outlets



SAFETY PRECAUTIONS

If ANY of the following conditions occurs, turn off your unit immediately!

- The power cord is damaged or abnormally warm
- You smell a burning odor
- The unit emits loud or abnormal sounds
- A power fuse blows or the circuit breaker frequently trips
- Water or other objects fall into or out of the unit

DO NOT ATTEMPT TO FIX THESE YOURSELF! CONTACT AN AUTHORIZED SERVICE PROVIDER IMMEDIATELY!

Common Issues

The following problems are not a malfunction and in most situations will not require repairs.

Issue	Possible Causes
Unit does not turn on when pressing ON/OFF button	The Unit has a 3-minute protection feature that prevents the unit from overloading. The unit cannot be restarted within three minutes of being turned off.
The unit changes from COOL/HEAT mode to FAN mode	The unit may change its setting to prevent frost from forming on the unit. Once the temperature increases, the unit will start operating in the previously selected mode again.
	The set temperature has been reached, at which point the unit turns off the compressor. The unit will continue operating when the temperature fluctuates again.
The indoor unit emits white mist	In humid regions, a large temperature difference between the room's air and the conditioned air can cause white mist.
Both the indoor and outdoor units emit white mist	When the unit restarts in HEAT mode after defrosting, white mist may be emitted due to moisture generated from the defrosting process.

Issue	Possible Causes
The indoor unit makes noises	A rushing air sound may occur when the louver resets its position.
	A squeaking sound may occur after running the unit in HEAT mode due to expansion and contraction of the unit's plastic parts.
Both the indoor unit and outdoor unit make noises	Low hissing sound during operation: This is normal and is caused by refrigerant gas flowing through both indoor and outdoor units.
	Low hissing sound when the system starts, has just stopped running, or is defrosting: This noise is normal and is caused by the refrigerant gas stopping or changing direction.
	Squeaking sound: Normal expansion and contraction of plastic and metal parts caused by temperature changes during operation can cause squeaking noises.
The outdoor unit makes noises	The unit will make different sounds based on its current operating mode.
Dust is emitted from either the indoor or outdoor unit	The unit may accumulate dust during extended periods of non-use, which will be emitted when the unit is turned on. This can be mitigated by covering the unit during long periods of inactivity.
The unit emits a bad odor	The unit may absorb odors from the environment (such as furniture, cooking, cigarettes, etc.) which will be emitted during operations.
	The unit's filters have become moldy and should be cleaned.
The fan of the outdoor unit does not operate	During operation, the fan speed is controlled to optimize product operation.
Operation is erratic, unpredictable, or unit is unresponsive	<p>Interference from cell phone towers and remote boosters may cause the unit to malfunction.</p> <p>In this case, try the following:</p> <ul style="list-style-type: none"> • Disconnect the power, then reconnect. • Press ON/OFF button on remote control to restart operation.

NOTE: If problem persists, contact a local dealer or your nearest customer service center. Provide them with a detailed description of the unit malfunction as well as your model number.

Troubleshooting

When troubles occur, please check the following points before contacting a repair company.

Problem	Possible Causes	Solution
Poor Cooling Performance	Temperature setting may be higher than ambient room temperature	Lower the temperature setting
	The heat exchanger on the indoor or outdoor unit is dirty	Clean the affected heat exchanger
	The air filter is dirty	Remove the filter and clean it according to instructions
	The air inlet or outlet of either unit is blocked	Turn the unit off, remove the obstruction and turn it back on
	Doors and windows are open	Make sure that all doors and windows are closed while operating the unit
	Excessive heat is generated by sunlight	Close windows and curtains during periods of high heat or bright sunshine
	Too many sources of heat in the room (people, computers, electronics, etc.)	Reduce amount of heat sources
	Low refrigerant due to leak or long-term use	Check for leaks, re-seal if necessary and top off refrigerant
SILENCE function is activated(optional function)	SILENCE function can lower product performance by reducing operating frequency. Turn off SILENCE function.	

Problem	Possible Causes	Solution
The unit is not working	Power failure	Wait for the power to be restored
	The power is turned off	Turn on the power
	The fuse is burned out	Replace the fuse
	Remote control batteries are dead	Replace batteries
	The Unit's 3-minute protection has been activated	Wait three minutes after restarting the unit
	Timer is activated	Turn timer off
The unit starts and stops frequently	There's too much or too little refrigerant in the system	Check for leaks and recharge the system with refrigerant.
	Incompressible gas or moisture has entered the system.	Evacuate and recharge the system with refrigerant
	The compressor is broken	Replace the compressor
	The voltage is too high or too low	Install a manostat to regulate the voltage
Poor heating performance	The outdoor temperature is extremely low	Use auxiliary heating device
	Cold air is entering through doors and windows	Make sure that all doors and windows are closed during use
	Low refrigerant due to leak or long-term use	Check for leaks, re-seal if necessary and top off refrigerant
Indicator lamps continue flashing	<p>The unit may stop operation or continue to run safely. If the indicator lamps continue to flash or error codes appear, wait for about 10 minutes. The problem may resolve itself. If not, disconnect the power, then connect it again. Turn the unit on.</p> <p>If the problem persists, disconnect the power and contact your nearest customer service center.</p>	
<p>Error code appears in the window display of indoor unit:</p> <ul style="list-style-type: none"> • E0, E1, E2... • P1, P2, P3... • F1, F2, F3... 		

NOTE: If your problem persists after performing the checks and diagnostics above, turn off your unit immediately and contact an authorized service center.

European Disposal Guidelines

5

This appliance contains refrigerant and other potentially hazardous materials. When disposing of this appliance, the law requires special collection and treatment. Do not dispose of this product as household waste or unsorted municipal waste.

When disposing of this appliance, you have the following options:

- Dispose of the appliance at designated municipal electronic waste collection facility.
- When buying a new appliance, the retailer will take back the old appliance free of charge.
- The manufacturer will take back the old appliance free of charge.
- Sell the appliance to certified scrap metal dealers.

Special notice

Disposing of this appliance in the forest or other natural surroundings endangers your health and is bad for the environment. Hazardous substances may leak into the ground water and enter the food chain.

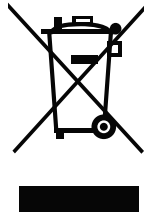

The design and specifications are subject to change without prior notice for product improvement. Consult with the sales agency or manufacturer for details.



CLIVET SPA

Via Camp Lonc 25, Z.I. Villapaiera - 32032 Feltre (BL) - Italy
Tel. + 39 0439 3131 - Fax + 39 0439 313300 - info@clivet.it

CLIVET GROUP UK Limited

4 Kingdom Close, Segensworth East - Fareham, Hampshire - PO15 5TJ - United Kingdom
Tel. + 44 (0) 1489 572238 - Fax + 44 (0) 1489 573033 - enquiries@clivetgroup.co.uk

CLIVET GROUP UK Limited (Service Department)

Units F5&F6 Railway Triangle Ind Est, Walton Road - Portsmouth, Hampshire - PO6 1TG - United Kingdom
Tel. +44 (0) 2392 381235 - Fax. +44 (0) 2392 381243 - service@clivetgroup.co.uk

CLIVET ESPAÑA S.A.U.

C/ Bac de Roda, 36 - 08019 Barcelona - España
Tel: +34 93 8606248 - Fax +34 93 8855392 - info@clivet.es

Av.Manoteras Nº 38, Oficina C303 - 28050 Madrid - España
Tel. +34 91 6658280 - Fax +34 91 6657806 - info@clivet.es

CLIVET GmbH (Hydronic and Applied Division)

Hummelsbütteler Steindamm 84, 22851 Norderstedt - Germany
Tel. + 49 (0) 40 32 59 57-0 - Fax + 49 (0) 40 32 59 57-194 - info.de@clivet.com

CLIVET GmbH (VRF, Residential and Lightcom Division)

Eisenstrasse 9c, 65428 Rüsselsheim/Frankfurt - Germany
Tel. + 49 (0) 6142 83594-0 - Fax + 49 (0) 6142 83594-20 - vrf.de@clivet.com

CLIVET RUSSIA

Elektrozavodskaya st. 24, office 509 - 107023, Moscow, Russia
Tel. + 74956462009 - Fax + 74956462009 - info.ru@clivet.com

CLIVET MIDEAST FZCO

Dubai Silicon Oasis (DSO), High Bay Complex, Office N. 20, PO BOX 342009, Dubai, UAE
Tel. + 9714 3208499 - Fax + 9714 3208216 - info@clivet.ae

CLIVET AIRCONDITIONING SYSTEMS PRIVATE LIMITED

4BA, Gundecha Onclave, Kherani Road - Sakinaka, Andheri (East) - Mumbai 400 072 - India
Tel. +91 22 6193 7000 - Fax +91 22 6193 7001 - info.in@clivet.com

The data contained in this manual is not binding and may be changed by the manufacturer without prior notice.
Reproduction, even in part, is FORBIDDEN © Copyright - CLIVET S.p.A. - Feltre (BL) - Italia

A Group Company of



www.clivet.com
www.clivetlive.com



MANUEL DE
L'UTILISATEUR

Télécommande de climatiseur



RG66B6 / PEKU00008



Change living home

TABLE DES MATIÈRES

Spécifications de la télécommande.....	2
Boutons de fonction.....	3
Utilisation de la télécommande.....	4
Indicateurs sur l'écran LCD de la télécommande.....	5
Comment utiliser les fonctions de base.....	6
Comment utiliser les fonctions avancées.....	13

Nous vous remercions vivement d'avoir acheté notre climatiseur. Veuillez lire attentivement ce manuel de l'utilisateur avant d'utiliser votre climatiseur. Veuillez à le conserver pour pouvoir vous y référer ultérieurement.

La conception et les spécifications peuvent être modifiées sans préavis afin d'améliorer le produit. Consultez votre vendeur ou le constructeur pour plus d détails

Spécifications de la télécommande

Modèle	RG66B6/BEGEF
Tension nominale	3,0 V (piles sèches R03/LR 03 2)
Plage de réception de signal	8 m
Environnement	-5° C ~60° C

NOTE :

- La disposition des boutons fournie ici est basée sur un modèle de base et peut différer légèrement de l'appareil que vous avez acheté. La forme réelle prévaut.
- Toutes les fonctions décrites sont exécutées par l'unité. Si l'unité n'est pas équipée de la fonction décrite, rien ne se passera lorsque vous enfoncez le bouton en question sur la télécommande.
- S'il existe d'importantes différences entre la description des fonctions de télécommande et du manuel de l'utilisateur, la description fournie par le manuel de l'utilisateur prévaudra.

Boutons de fonction

Avant de commencer à utiliser votre nouveau climatiseur, il est important de se familiariser avec sa télécommande. Vous trouverez ci-dessous une brève présentation de la télécommande proprement dite. Pour obtenir des informations relatives à l'utilisation de votre climatiseur, reportez-vous aux chapitres **Comment utiliser les fonctions de base/avancées** de ce manuel.

NOTE : Ne sélectionnez pas le mode HEAT si la machine que vous avez achetée est un modèle ne servant qu'au refroidissement. Le mode chauffage n'est pas pris en charge par l'appareil de refroidissement uniquement.

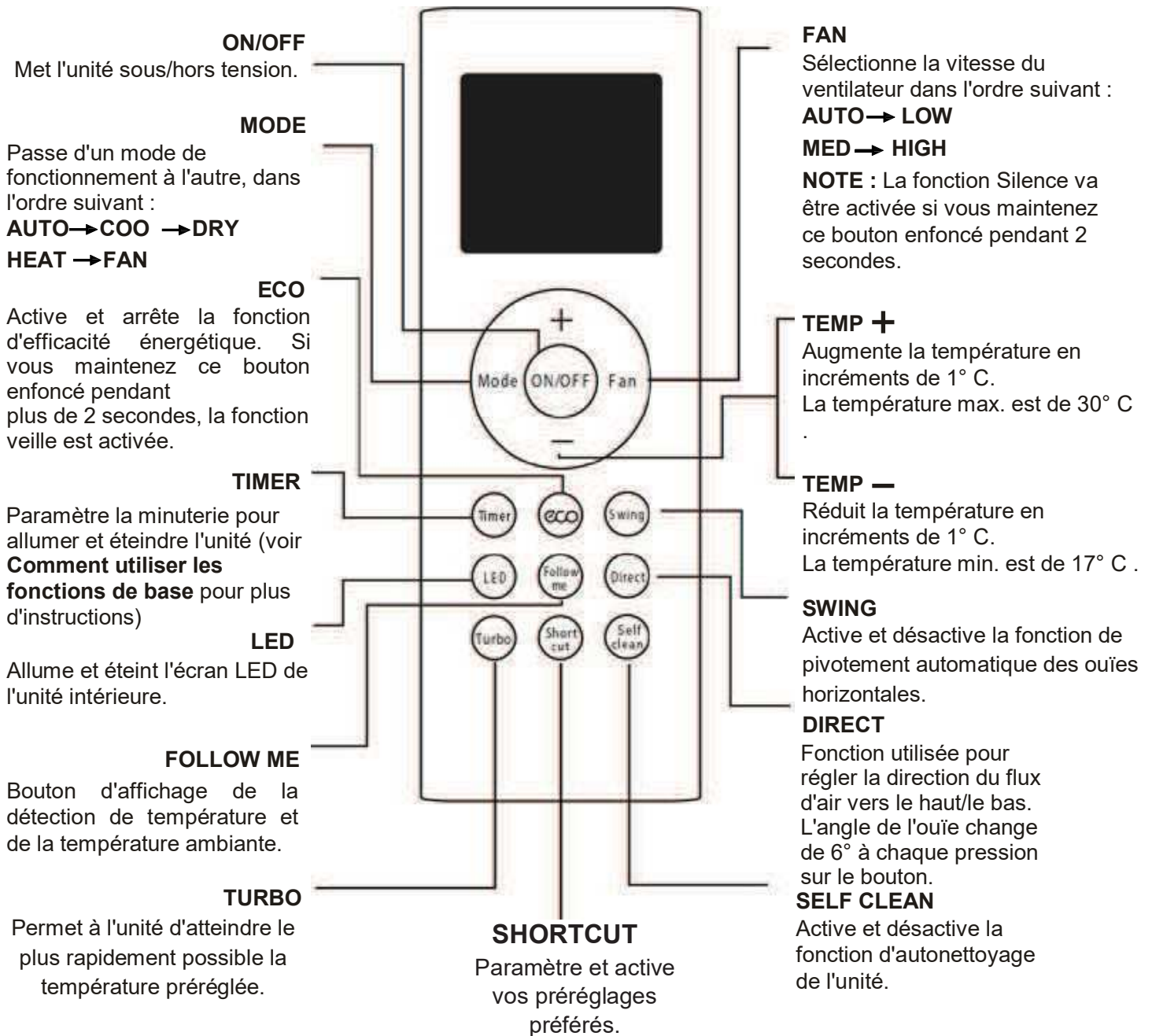

Utilisation de la télécommande

Vous ne savez pas à quoi une fonction sert ?

Reportez-vous aux chapitres **Comment utiliser les fonctions de base** et **Comment utiliser les fonctions avancées** de ce manuel pour obtenir une description détaillée de l'utilisation de votre climatiseur.

Remarque spéciale

- La disposition des boutons sur votre unité peut différer légèrement de l'exemple illustré.
- Si l'unité intérieure ne possède pas une des fonctions énumérées, rien ne se produira si vous enfoncez le bouton de cette fonction sur la télécommande.

Insertion et remplacement des piles

Votre climatiseur est fourni avec deux piles AAA. Placez les piles dans la télécommande avant de l'utiliser :

1. déposez le capot arrière de la télécommande pour ouvrir le compartiment à piles.
2. Insérez les batteries en respectant la polarité (+ et -) des piles par rapport aux symboles figurant à l'intérieur du compartiment à piles.
3. Remettez le capot en place.

Installation du support de télécommande

La télécommande peut être fixée sur un mur ou un pied en utilisant un support de télécommande (élément optionnel non fourni avec l'unité).

1. Avant d'installer la télécommande, assurez-vous que le climatiseur reçoit correctement le signal.
2. Installez le support avec deux vis.
3. Placez la télécommande dans son support.

! Notes relatives aux piles

Pour garantir des performances

- **optimales du produit** : Ne mélangez pas d'anciennes piles avec de nouvelles piles, ni des piles de types différents.
- Ne laissez pas les piles dans la télécommande si vous prévoyez de ne pas utiliser celle-ci pendant plus de deux mois.



Mise au rebut des piles

pour les ménagers. Reportez-vous à la législation locale concernant la mise au rebut des piles.

Conseils d'utilisation de la

- La télécommande doit être utilisée à moins de 8 mètres de l'unité.
- L'unité va émettre un bip lorsqu'elle capte le signal.
- Des rideaux, d'autres matériaux et les rayons directs du soleil peuvent interférer avec le récepteur de signal infrarouge.
- Retirez les piles si vous prévoyez de ne pas utiliser la télécommande pendant plus de deux mois.

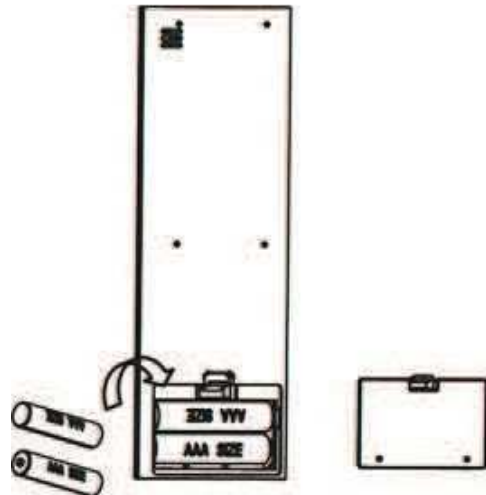

Déposez le capot arrière pour installer les piles.

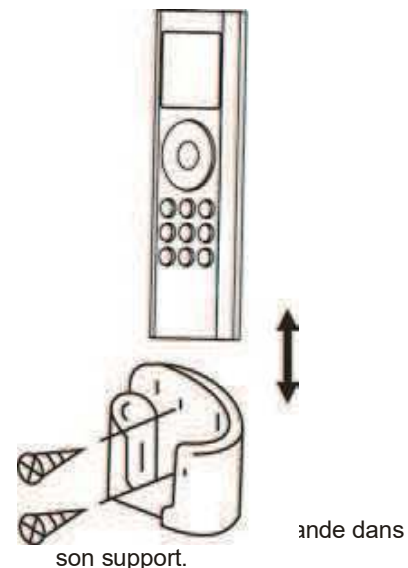

Indicateurs sur l'écran LCD de la télécommande

Des informations s'affichent à l'écran lorsque la télécommande est mise sous tension.

Écran marche/arrêt (ON/OFF)

S'affiche lorsque l'unité est mise sous tension. S'éteint lorsque l'unité est mise hors tension.

Indicateur de transmission S'allume lorsque la télécommande envoie un signal à l'unité intérieure

Affichage MODE

Affiche le mode en cours, y compris :



Affichage TIMER ON

() S'affiche lorsque TIMER ON est activée.

Affichage TIMER OFF

() S'affiche lorsque MINUTERIE DÉSACTIVÉE est activée.

eco S'affiche lorsque la fonction ECO est activé.

Affichage de la batterie. Détection de batterie faible

Affichage de la Température/Timer

Affiche la température réglée par défaut, ou le réglage de la minuterie en utilisant les fonctions **TIMER ON/OFF**.

- Plage de températures : 17-30 °C
- Plage de réglages de la minuterie : 0-24 heures



L'affichage est vierge lorsque le mode ventilateur est activé.

Affichage de la vitesse du ventilateur Affichage la vitesse de ventilateur sélectionnée :

-  Vitesse basse
-  Vitesse moyenne
-  Vitesse élevée
-  AUTO/vitesse auto

Cette vitesse de ventilateur ne peut pas être réglée en mode AUTO ou DRY.

-  Affichage de la fonction Silence
-  Affichage de la fonction Follow me
-  Affichage de la fonction VERROUILLAGE

-  Non disponible pour cette unité.
-  Non disponible pour cette unité.
-  Affichage du mode Veille

Remarque :

Tous les indicateurs montrés à la figure sont destinés à faciliter la présentation. Pendant le fonctionnement proprement dit, seuls les signaux fonctionnels relatifs s'affichent dans la fenêtre.

Comment utiliser les fonctions de base

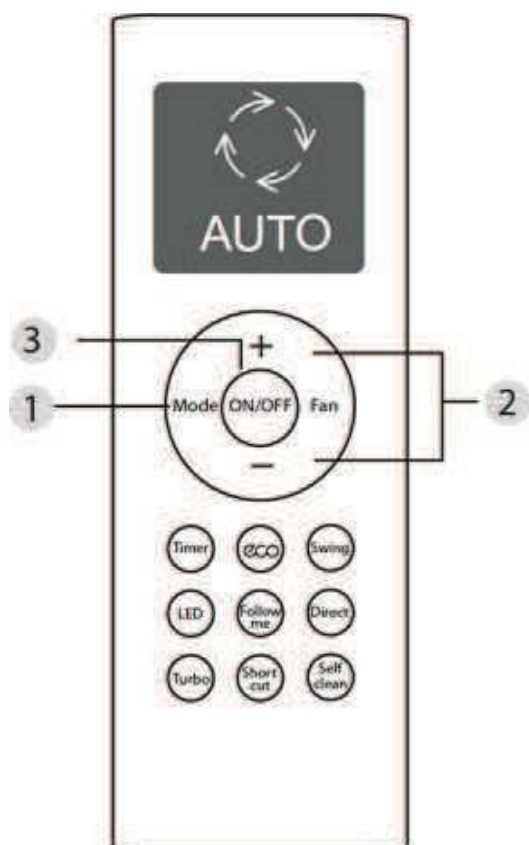

Réglage de la température

La plage de températures de service va de 17 à 30° C. Vous pouvez augmenter ou diminuer la température paramétrée en incréments de 1° C.

Mode AUTO

En mode **AUTO**, l'unité va sélectionner automatiquement le mode COOL, FAN, HEAT ou DRY en fonction de la température paramétrée.

1. Enfoncez le bouton **MODE** pour sélectionner le mode Auto.
2. Réglez la température souhaitée en utilisant le bouton **Temp** **+** ou **Temp** **-**.
3. Enfoncez le bouton **ON/OFF** pour démarrer l'unité.

NOTE : la vitesse du ventilateur ne peut pas être réglée en mode Auto.

Mode COOL

1. Enfoncez le bouton **MODE** pour sélectionner le mode **COOL**.
2. Réglez la température souhaitée avec le bouton **Temp** **+** ou **Temp** **-**.
3. Enfoncez le bouton **FAN** pour sélectionner la vitesse du ventilateur.
4. Enfoncez le bouton **ON/OFF** pour démarrer l'unité.

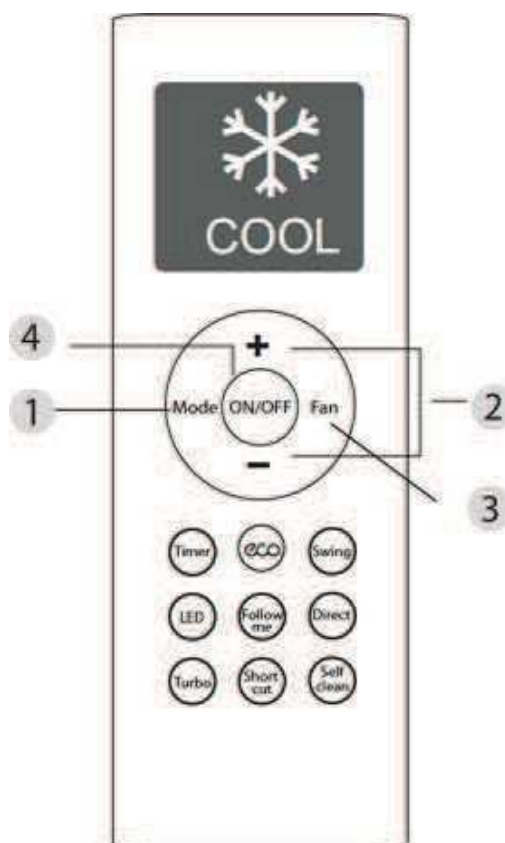

Comment utiliser les fonctions de base

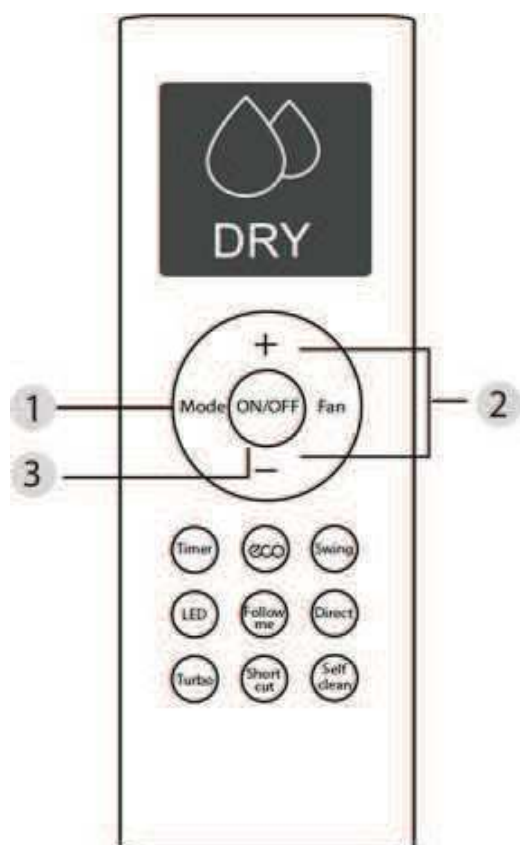

Mode DRY (déshumidification)

1. Enfoncez le bouton **MODE** pour sélectionner le mode **DRY**.
2. Réglez la température souhaitée en utilisant le bouton **Temp -** ou **Temp +**.
3. Enfoncez le bouton **ON/OFF** pour démarrer l'unité.

NOTE : la vitesse du ventilateur ne peut pas être modifiée en mode DRY.

Mode FAN

1. Enfoncez le bouton **MODE** pour sélectionner le mode FAN.
2. Enfoncez le bouton **FAN** pour sélectionner la vitesse du ventilateur.
3. Enfoncez le bouton **ON/OFF** pour démarrer l'unité.

NOTE : Vous ne pouvez pas modifier la température en mode FAN L'écran LCD de votre télécommande n'affichera pas la

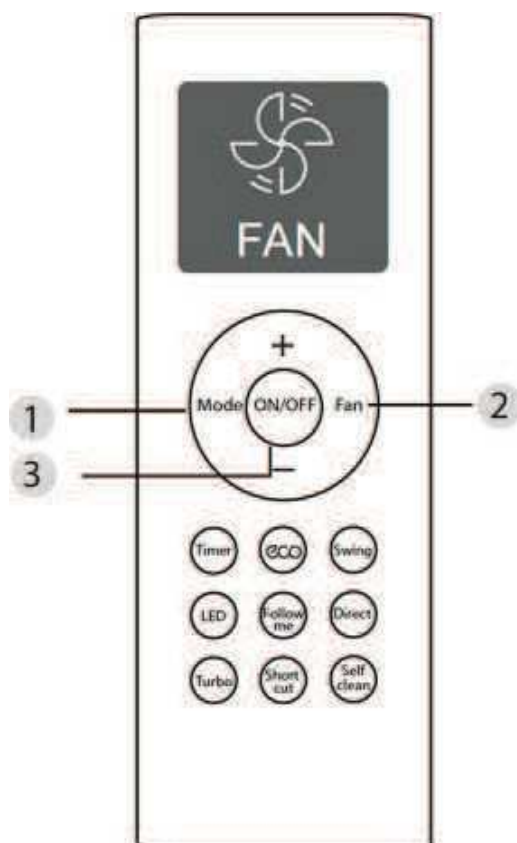

Comment utiliser les fonctions de base

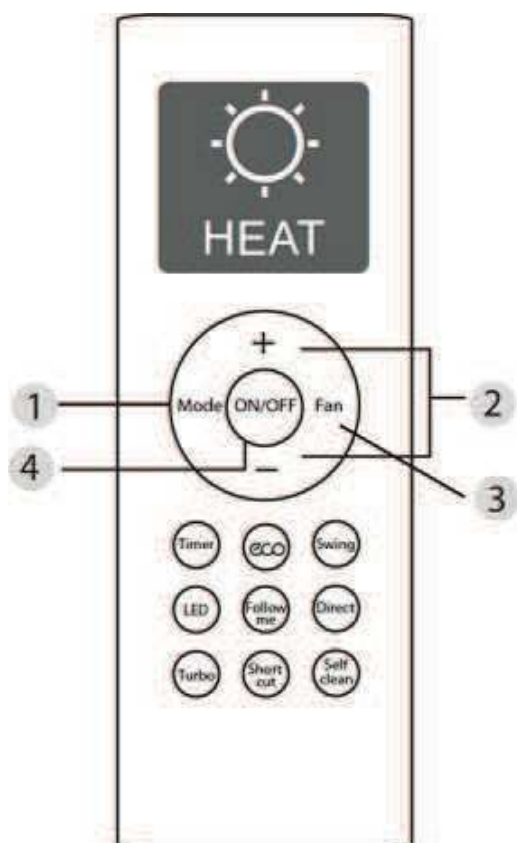

Mode HEAT

1. Enfoncez le bouton **MODE** pour sélectionner le mode **HEAT**.
2. Réglez la température souhaitée avec le bouton **Temp** **-** ou **Temp** **+**.
3. Enfoncez le bouton **FAN** pour sélectionner la vitesse du ventilateur.
4. Enfoncez le bouton **ON/OFF** pour démarrer l'unité.

NOTE : Les performances de la fonction HEAT de votre unité peuvent être affectées par la baisse de la température extérieure. Dans ce cas de figure, nous vous recommandons d'utiliser ce climatiseur

Paramétrage de la fonction

Votre unité de climatisation possède deux fonctions liées à la minuterie :

- **TIMER ON** - permet de régler la durée après laquelle l'unité va s'allumer automatiquement.
- **TIMER OFF** - permet de régler la durée après laquelle l'unité va s'éteindre automatiquement.

Fonction TIMER ON

La fonction **TIMER ON** vous permet de paramétrer une période de temps après laquelle l'unité va s'allumer automatiquement, par exemple lorsque vous rentrez du travail.

1. Enfoncez le bouton **Timer**, l'indicateur

Timer «  ON » va se mettre à clignoter.

Par

défaut, la dernière période de temps que vous avez paramétrée et un « h » (indiquant les heures) vont s'afficher à l'écran.

Remarque : Ce nombre indique la durée au bout de laquelle vous souhaitez que l'unité se mette en marche.

Par exemple, si vous avez réglé **TIMER ON**

2,5 sur « 2.5h » va s'afficher à l'écran, heures, »

et l'unité va démarrer au bout de 2,5 heures.

2. Enfoncez le bouton **Temp+** ou **Temp-** plusieurs fois pour paramétrer l'heure à laquelle vous souhaitez que l'unité se mette en marche.
3. Attendez 3 secondes pour que la fonction **TIMER ON** soit activée.

L'affichage

numérique de la télécommande va ensuite revenir à l'affichage de la température.

L'indicateur

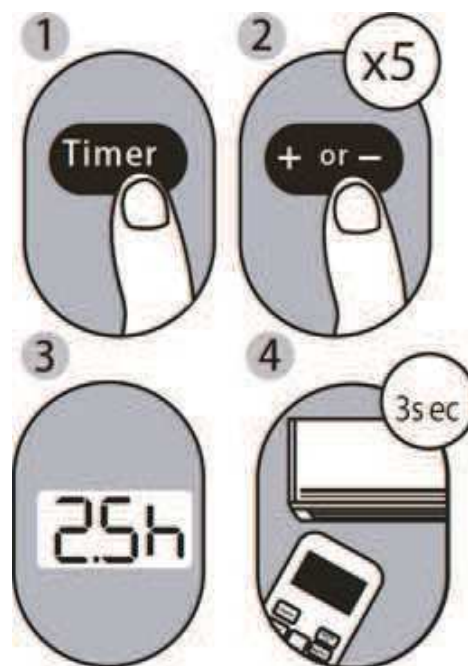

«  ON » reste allumé et cette fonction est activée.



Exemple : paramétrer l'unité pour qu'elle se mette en marche au bout de 2,5 h.

Fonction TIMER OFF

La fonction **TIMER OFF** vous permet de paramétrer la durée au bout de laquelle l'unité va s'arrêter automatiquement, par exemple lorsque vous vous levez.

1. Enfoncez le bouton **Timer**, l'indicateur Timer off «  OFF » s'affiche et clignote. Par défaut, la dernière période de temps que vous avez paramétrée et un « h » (pour heures) va s'afficher à l'écran.
Remarque : Ce nombre indique la durée au bout de laquelle vous souhaitez que l'unité s'arrête. Par exemple, si vous avez réglé **TIMER OFF** pour 5 heures, « 5.0h » va s'afficher à l'écran, et l'unité va démarrer au bout de 5 heures.
2. Enfoncez le bouton **Temp +** ou **Temp -** plusieurs fois pour paramétrer l'heure à laquelle vous souhaitez que l'unité s'allume.
3. Attendez 3 secondes pour que la fonction **TIMER OFF** soit activée. L'affichage numérique de la télécommande va ensuite revenir à l'affichage de la température. L'indicateur «  OFF » reste allumé et cette fonction est activée.

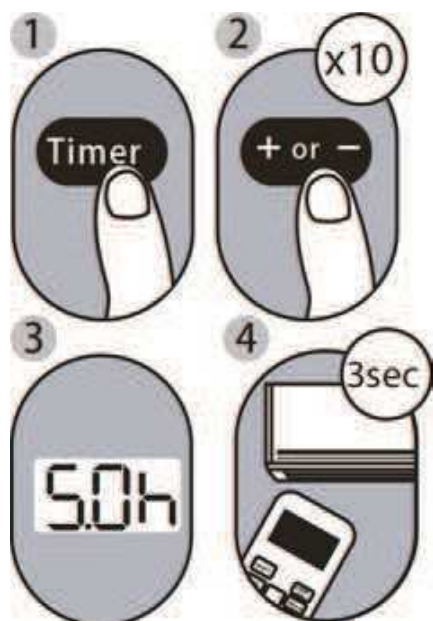

Exemple : paramétrer l'unité pour qu'elle s'éteigne au bout de 5 h.

NOTE : Lorsque vous paramétrez les fonctions **TIMER ON** ou **TIMER OFF**, la durée va augmenter en incréments de 30 minutes jusqu'à 10 heures à chaque pression. Après 10 heures et jusqu'à 24 heures, la durée va augmenter en incréments d'une heure. La durée va revenir à zéro au bout de 24 heures. Vous pouvez désactiver chacune de ces fonctions en paramétrant sa minuterie sur « 0.0h ».

Paramétrage simultané de TIMER ON et TIMER OFF

N'oubliez pas que les périodes de temps que vous paramétrez pour les deux fonctions font référence aux heures qui s'écoulent après l'heure du moment. Supposons qu'il soit actuellement 13h00 et que vous souhaitez que l'unité se mette automatiquement en marche à 19h00. Vous souhaitez en outre qu'elle fonctionne pendant 2 heures et s'éteigne automatiquement à 21h00. Voici la marche à

suivre :

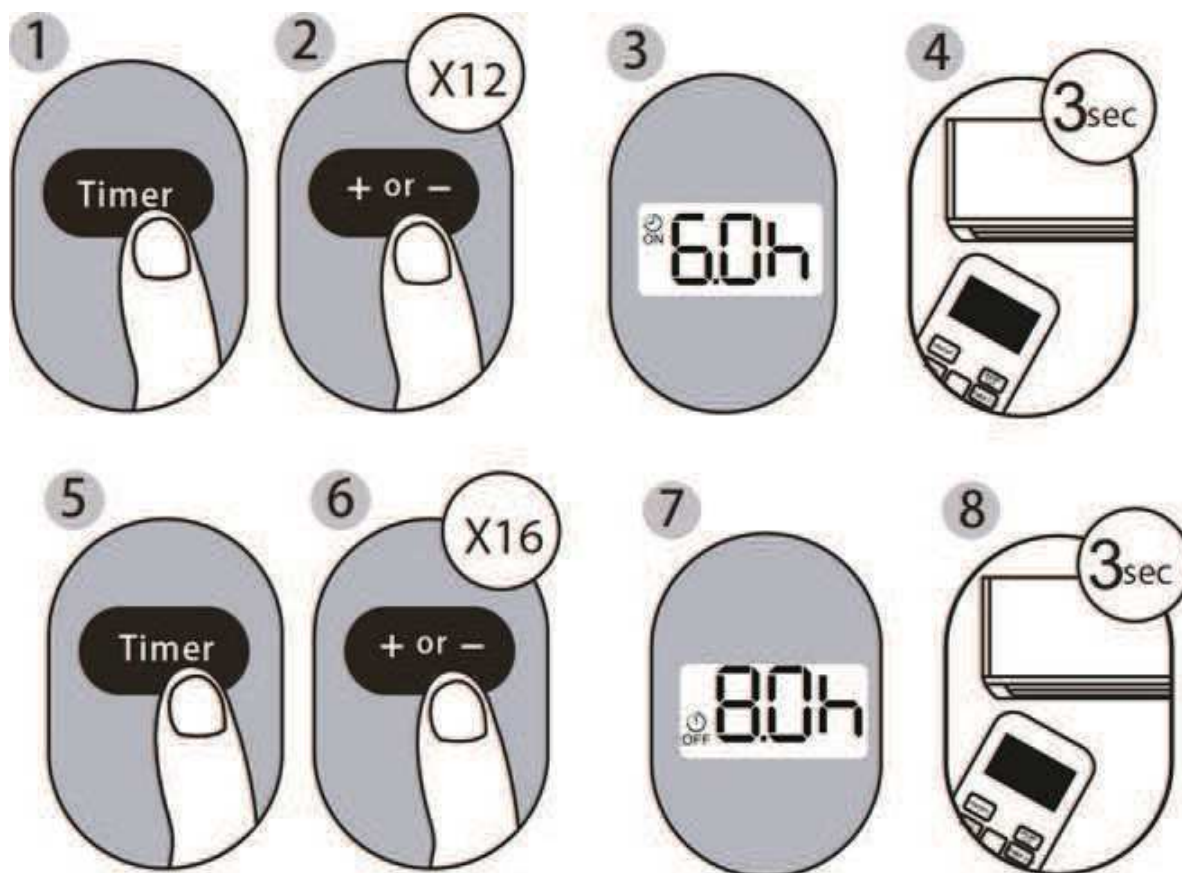

Exemple : Paramétrez l'unité pour qu'elle se mette en marche au bout de 6 heures, et fonctionne pendant 2 heures avant de s'éteindre (voir l'illustration figure ci-dessous).

L'écran de votre télécommande



La minuterie est réglée pour se mettre en marche dans 6 heures à partir de ce

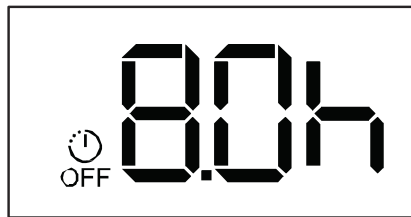

La minuterie est réglée pour s'éteindre dans 8 heures à partir de ce

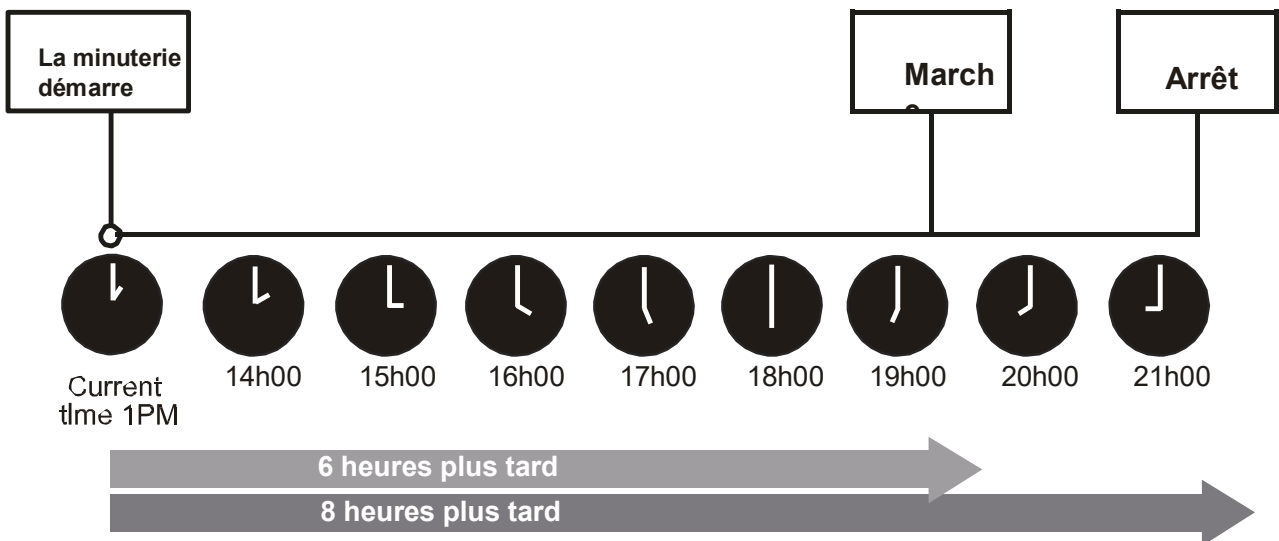

Comment utiliser les fonctions avancées

Fonction ECO

NOTE : Cette fonction n'est disponible qu'en mode COOL.

- Elle est utilisée pour accéder au mode d'économie d'énergie. Enfoncez ce bouton en mode refroidissement. La télécommande va régler automatiquement la température sur 24° C, la vitesse du ventilateur sur Auto pour économiser l'énergie (mais uniquement si la température choisie est inférieure à 24° C). Si la température choisie est supérieure à 24° C, enfoncez le bouton ECO. La vitesse du ventilateur va passer sur Auto, la température paramétrée va rester inchangée.

NOTE :

- Enfoncez le bouton ECO, modifier le mode ou régler la température paramétrée sur moins de 24° C va arrêter le mode ECO.
- En mode ECO, la température choisie doit être de 24° C ou plus. Elle peut se traduire par un refroidissement insuffisant. Si vous ne vous sentez pas à l'aise, il suffit d'enfoncer à nouveau le bouton ECO pour l'arrêter.

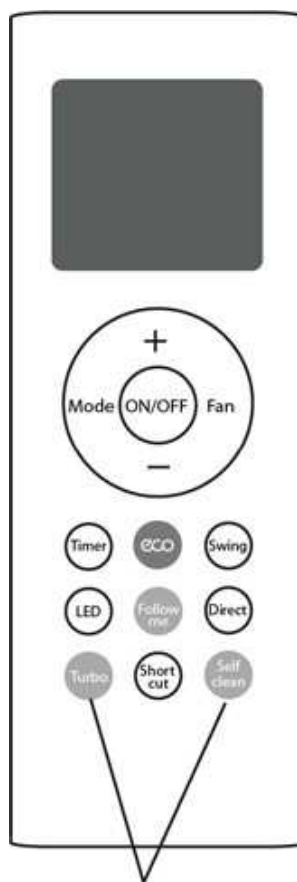

Maintenez les deux boutons ensemble une seconde pour activer la fonction de verrouillage.

Fonction SLEEP

La fonction SLEEP est utilisée pour réduire la consommation d'énergie pendant que vous dormez (et ne nécessite pas le même réglage de température pour créer une ambiance confortable). Cette fonction ne peut être activée que via la télécommande.

Pour plus de détails, reportez-vous au mode Sleep dans le manuel de l'utilisateur .

Remarque : La fonction SLEEP n'est pas disponible en mode FAN ou DRY.

Fonction Follow me

La fonction Follow me permet à la télécommande de mesurer la température à l'endroit où elle se trouve et d'envoyer ce signal au climatiseur toutes les trois minutes. En mode AUTO, COOL ou HEAT, mesurer la température ambiante à partir de la télécommande (et non depuis l'unité intérieure elle-même) va permettre au climatiseur d'optimiser la température autour de vous et d'assurer un confort maximum.

Fonction LOCK

Enfoncez les boutons Turbo et Self clean simultanément pendant une seconde pour verrouiller ou déverrouiller le clavier.

Fonction TURBO

La fonction TURBO augmente la puissance de l'unité pour atteindre la température actuelle le plus rapidement possible.

- Si vous sélectionnez la fonction **TURBO** en mode COOL, l'unité souffle de l'air froid au maximum de sa puissance pour démarrer le plus rapidement possible le processus de refroidissement.
- Si vous sélectionnez la fonction **TURBO** en mode HEAT (pour les unités équipés d'éléments chauffants électriques), le chauffage électrique est activé pour démarrer le plus rapidement possible le processus de chauffage.

Comment utiliser les fonctions avancées

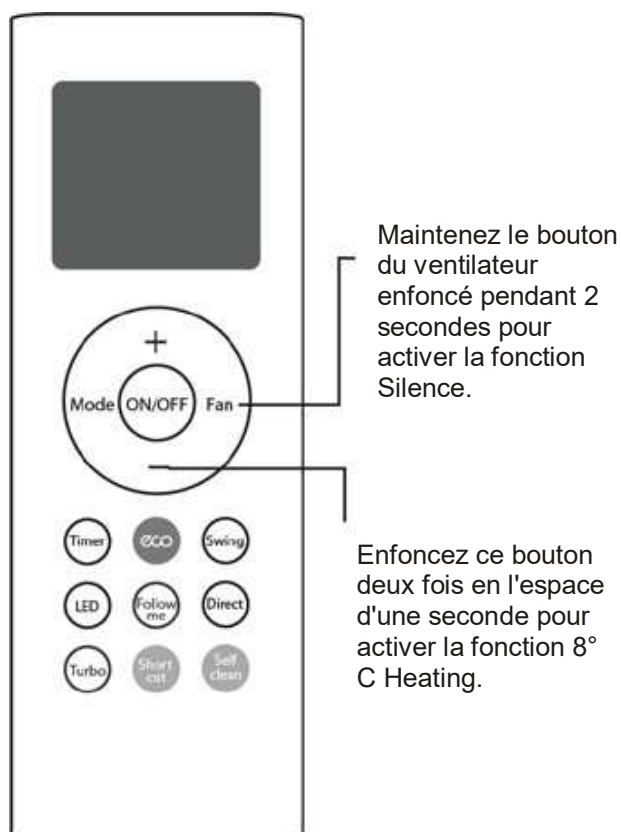

Fonction SHORTCUT

- Cette fonction est utilisée pour rétablir les paramètres actuels ou poursuivre des réglages précédents.
- Si vous enfonchez ce bouton lorsque la télécommande est activée, le système va automatiquement revenir aux réglages précédents, y compris le mode de fonctionnement, la température de réglage, la vitesse du ventilateur et la fonction veille (si elle est activée).
- Si vous enfonchez le bouton pendant plus de 2 secondes, le système va automatiquement restaurer les paramètres opérationnels actuels, y compris le mode de fonctionnement, la température de réglage, la vitesse du ventilateur et la fonction veille (si elle est activée).

Fonction Silence

Maintenez le bouton du ventilateur enfoncé pendant 2 secondes pour activer/annuler le mode **Silence**. En raison du fonctionnement à basse fréquence du compresseur, cela peut se traduire par une capacité de refroidissement et de chauffage insuffisante (pour climatiseur équipé de la fonction Silence uniquement).

Fonction 8°C Heating

Lorsque le climatiseur fonctionne en mode chauffage avec une température réglée de 17° C, vous pouvez activer la fonction 8° C Heating en enfonçant deux fois sur le bouton Temp en l'espace d'une seconde. L'unité va fonctionner à une température de réglage de 8° C. L'unité intérieure affichera « FP ».

Fonction Self Clean

Des bactéries en suspension peuvent se développer dans l'humidité qui se condense autour de l'échangeur de chaleur dans l'unité. Lorsque vous utilisez régulièrement l'appareil, la majeure partie de cette humidité s'évapore de l'unité.

Lorsque la fonction d'autonettoyage est activée, votre unité va se nettoyer automatiquement. Après le nettoyage, l'unité va s'éteindre automatiquement.

Vous pouvez utiliser la fonction d'autonettoyage aussi souvent que vous le désirez.

Remarque : Vous ne pouvez activer cette fonction qu'en mode COOL ou DRY.

Gestion via kit Wi-Fi et appli NetHome Plus

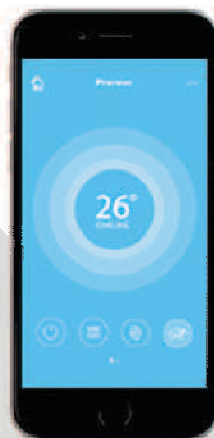

NWMX/PEKU00002



Change living home

TABLE DES MATIÈRES

1 SPÉCIFICATIONS	3
2 PRÉCAUTIONS	3
3 TÉLÉCHARGEMENT ET INSTALLATION DE L'APPLI	4
4 INSTALLATION DU KIT WI-FI.....	5
5 INSCRIPTION DE L'UTILISATEUR	6
6 CONFIGURATION DU RÉSEAU	7
7 COMMENT UTILISER L'APPLI	15
8 FONCTIONS SPÉCIALES.....	17

DÉCLARATION DE CONFORMITÉ

Nous déclarons par le présente que cette unité répond aux exigences essentielles et aux autres dispositions de la Directive 1999/5/CE. La déclaration de conformité peut être consultée auprès de l'agent commercial.

NOTE IMPORTANTE :

Veillez lire attentivement le manuel avant d'installer et de connecter votre kit Wi-Fi. Veillez à le conserver pour pouvoir vous y référer ultérieurement.

1 SPÉCIFICATIONS DU MODULE WI-FI

Modèle : OSK102

Standard : IEEE 802. 11big/n

Type d'antenne : Antenne externe

omnidirectionnelle Fréquence : Wi-Fi 2,4G

Puissance de transmission maximum :

Température 15 dBm de service maximum : 0°

C~45° C/32° F~113° F Taux d'humidité

opérationnelle : 10 %~85 %

Puissance absorbée : 5 V CC/300 mA

2 PRÉCAUTIONS

Système d'exploitation : iOS, Android.

(recommandé : iOS 7.0, Android 4.0)

Notes :

- L'appli ne prend pas en charge la dernière version logicielle du système Android et iOS.
- Nous insistons expressément sur le fait que : Tous les systèmes Android et iOS ne sont pas compatibles avec l'appli. Nous déclinons toute responsabilité en cas de problèmes résultant d'une incompatibilité.

Stratégie de sécurité sans fil

- Le kit Wi-Fi prend uniquement en charge le codage WPA-PSK/WPA2-PSK ou aucun codage. Le codage WPA-PSK/WPA2-PSK est recommandé.

Attention

- Veuillez vérifier le site web de service pour plus d'informations.
- Les caméras de smartphones doivent offrir 5 millions de pixels ou plus pour un scannage correct du code QR.
- En raison des configurations différentes des réseaux,

un retard dans la demande peut parfois se produire. Il est alors nécessaire de reconfigurer le réseau.

- En raison des configurations différentes des réseaux, le processus de contrôle peut parfois donner un retard. Si cela se produit, l'affichage de la carte et de l'appli peut être différent. Ne vous laissez pas induire en erreur.

NOTE : L'entreprise décline toute responsabilité en cas de problèmes dus à l'Internet, au routeur Wi-Fi ou à des appareils intelligents. Veuillez contacter le fournisseur d'origine pour plus d'aide.

3 **TÉLÉCHARGEMENT ET INSTALLATION DE L'APPLI**

Attention : Seuls le code QR A et le code QR B peuvent être utilisés pour télécharger l'appli.



Utilisateurs de téléphone Android : scannez le code QR A ou allez dans google play, recherchez l'appli « NetHome Plus » et téléchargez-la.

Utilisateurs de téléphone Android : scannez le code QR B ou allez dans Google Play, recherchez l'appli « NetHome Plus » et téléchargez-le.

4 INSTALLATION DU KIT WI-FI

1) Retirez le capuchon de protection du kit Wi-Fi.

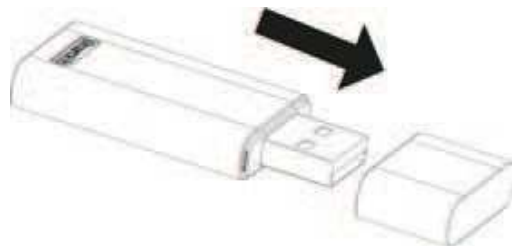

2) Ouvrez la façade et insérez le kit Wi-Fi dans l'interface réservée.

3) Collez le code QR fourni avec le kit Wi-Fi sur le panneau latéral de la machine, assurez-vous qu'elle est facile à scanner avec le téléphone portable. L'utilisateur peut alternativement prendre une photo du code QR et l'enregistrer dans son propre téléphone.

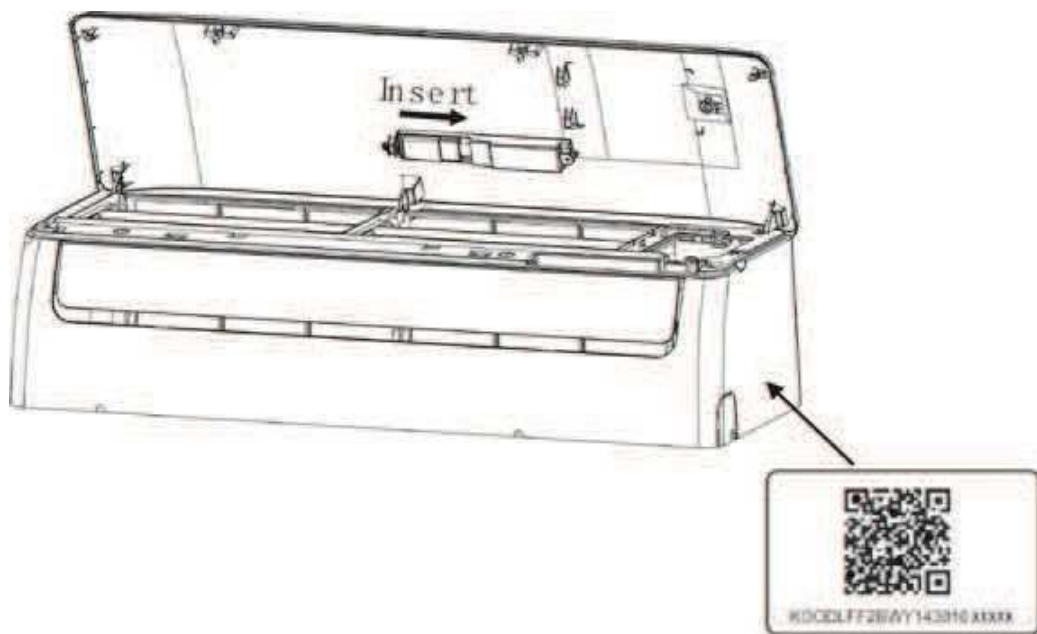

AVERTISSEMENT :

Cette interface n'est compatible qu'avec le kit Wi-Fi fourni par le constructeur.

5 INSCRIPTION DE L'UTILISATEUR

- Assurez-vous que votre appareil mobile est connecté au routeur Wi-Fi. Assurez-vous également que le routeur Wi-Fi est déjà connecté à l'Internet avant de procéder à l'inscription de l'utilisateur et à la configuration du réseau.
- Si vous avez oublié votre mot de passe, il est préférable d'ouvrir une session dans votre boîte aux lettres électronique et d'activer votre compte d'inscription en cliquant sur le lien.

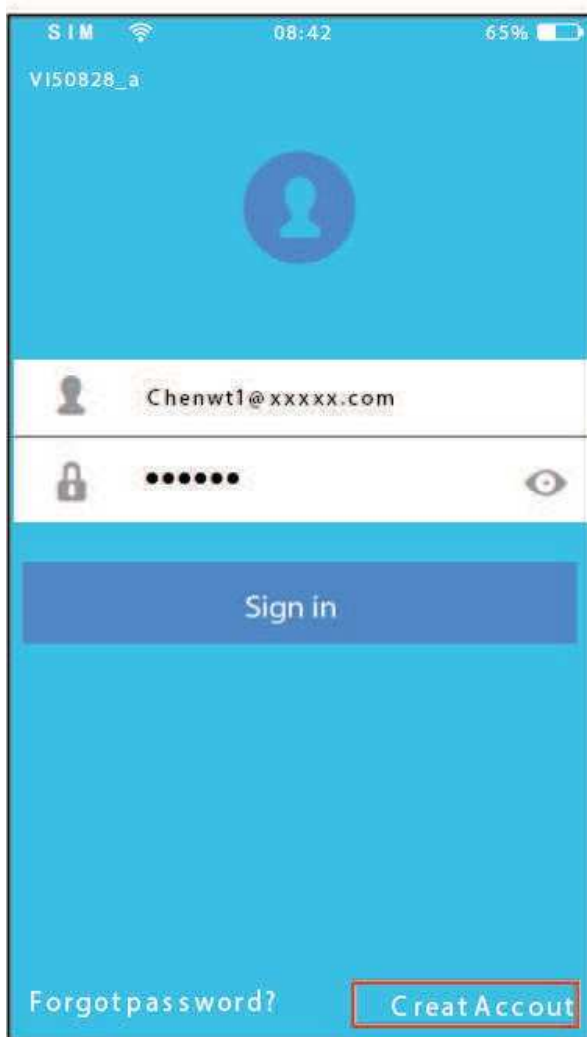

① Cliquez sur « Créer un compte ».

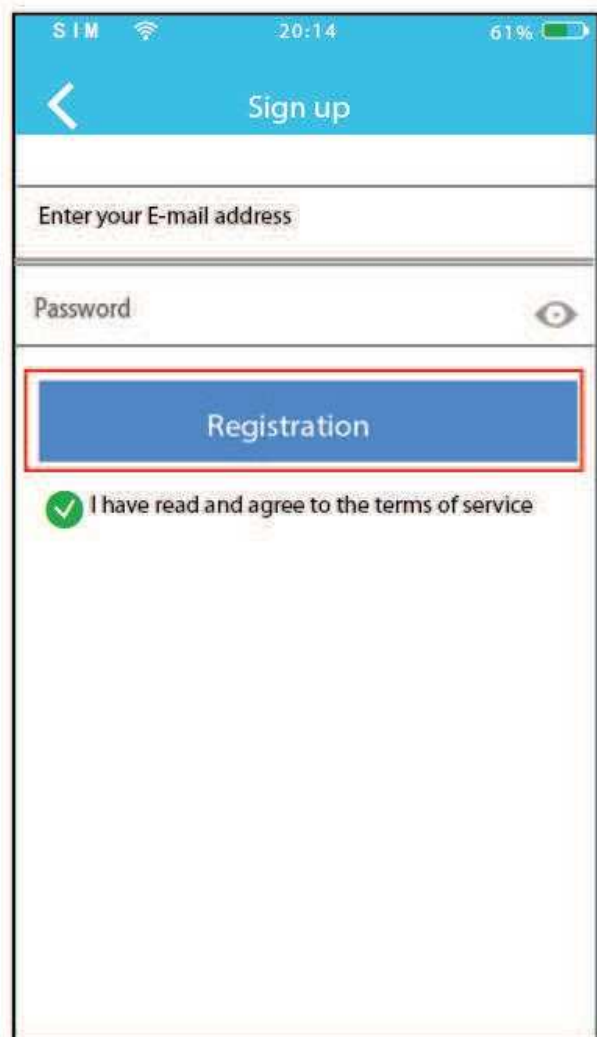

② Saisissez votre adresse électronique et votre mot de passe, puis cliquez sur « Inscription ».

6 CONFIGURATION DU RÉSEAU

Attention :

- Il est nécessaire d'utiliser tous les autres réseaux voisins et de vous assurer que votre appareil Android ou iOS se connecte uniquement au réseau Wi-Fi que vous souhaitez configurer.
- Assurez-vous que le Wi-Fi de l'appareil Android ou iOS fonctionne correctement et peut être reconnecté automatiquement à votre réseau Wi-Fi original.

Rappel :

- Lorsque l'unité entre en mode « AP », le contrôleur à distance de l'unité ne peut plus la commander. Il est nécessaire de terminer la configuration du réseau ou de remettre l'unité sous tension pour le vérifier. Vous pouvez également attendre 8 minutes pour permettre à l'unité de quitter automatiquement le mode « AP ».

■ Utilisation d'un appareil Android pour configurer le

- ① **réseau** Assurez-vous également que votre appareil mobile a déjà été connecté au réseau Wi-Fi que vous souhaitez utiliser. Vous devez également oublier tous les réseaux Wi-Fi non pertinents pour éviter qu'ils n'influencent votre processus de configuration.
- ② Déconnectez l'alimentation électrique de l'unité.
- ③ Connectez l'alimentation électrique et maintenez le bouton l'affichage numérique ou « **LED** » enfoncé sept fois en l'espace de trois minutes.
- ④ Lorsque l'écran affiche « AP », cela signifie que l'unité est déjà entrée en mode « AP ».

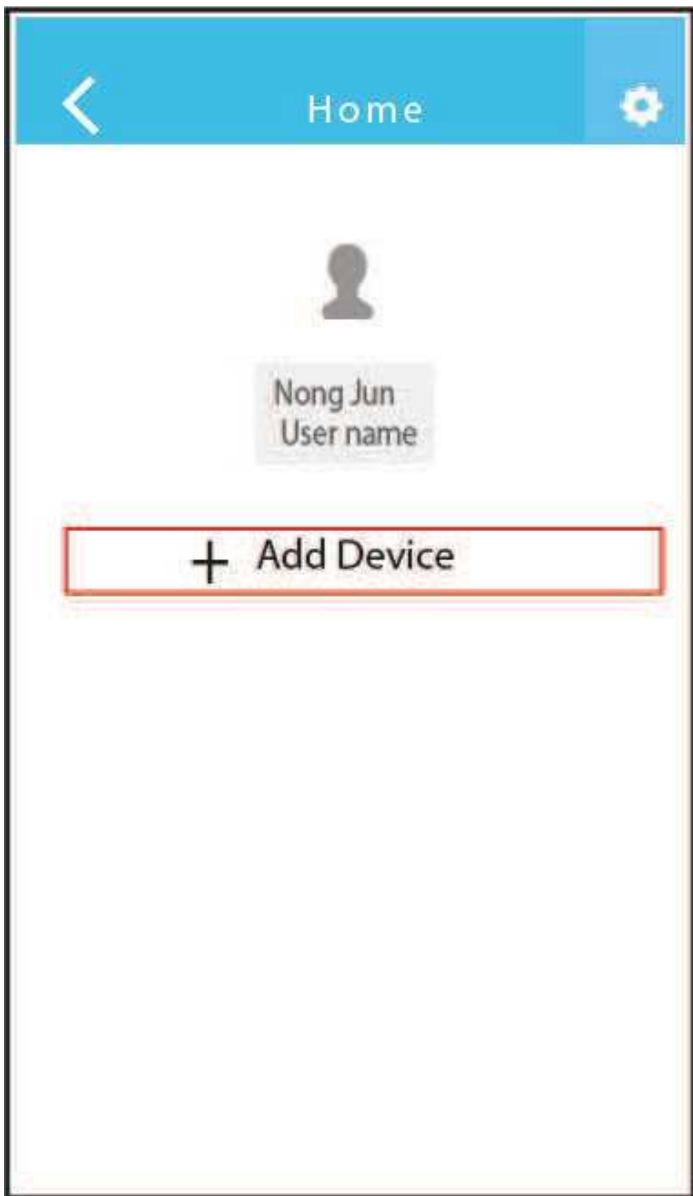

- ⑤ Appuyez sur « + Add Device »
- ⑥ Scannez le code QR fourni avec le kit Wi-Fi



- ⑦ Sélectionnez votre propre réseau Wi-Fi, par exemple Ma Maison (photo fournie uniquement à titre de référence).
- ⑧ Saisissez le mot de passe de votre routeur Wi-Fi et cliquez sur OK ;
- ⑨ La configuration a réussi, vous pouvez voir apparaître l'appareil dans la liste.

■ Utilisation d'un appareil iOS pour configurer le réseau

① Assurez-vous que votre appareil mobile a déjà été connecté au réseau Wi-Fi que vous souhaitez utiliser.

Vous devez également oublier tous les réseaux Wi-Fi non pertinents pour éviter qu'ils n'influencent votre processus de configuration.

② Déconnectez l'alimentation électrique de l'unité.

③ Connectez l'alimentation électrique et maintenez le bouton l'affichage numérique ou « **LED** » enfoncé sept fois en l'espace de trois minutes.

④ Lorsque l'écran affiche « AP », cela signifie que l'unité est déjà entrée en mode « AP ».

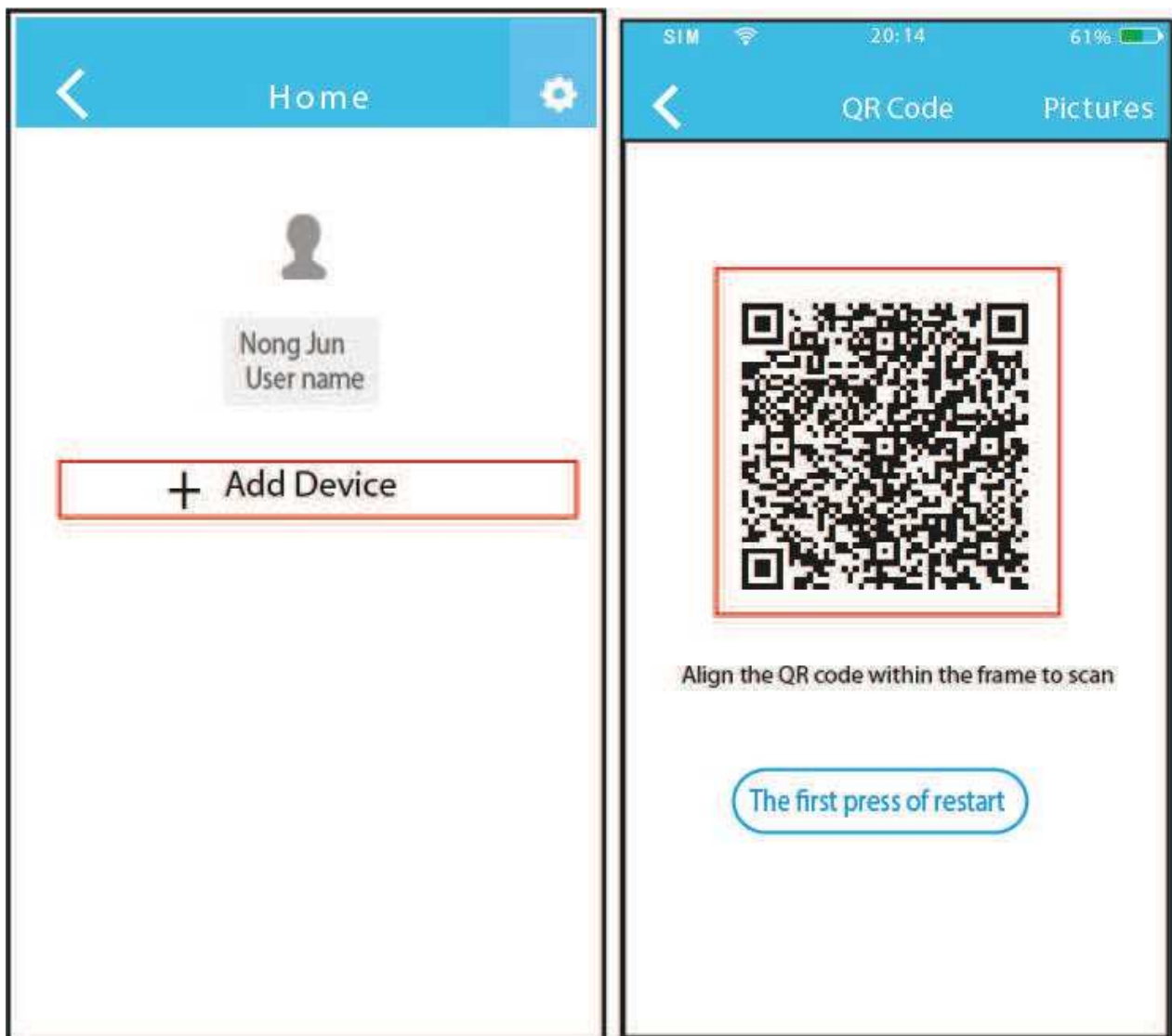

⑤ Appuyez sur « + Add Device »

⑥ Scannez le code QR fourni avec le smart kit.



⑦ Lisez les instructions qui précèdent et appuyez sur le bouton « Home » pour revenir à l'interface de l'appareil.

⑧ Cliquez sur « Settings » pour entrer dans la page de réglages, puis sélectionnez WLAN/WIFI.





⑨ Choisissez
net_ac_XXXX



⑩ Saisissez le mot de
passe par défaut :
12345678 et cliquez sur
« Join ».



⑪ Revenez à l'appli et cliquez sur « Next ».

⑫ Sélectionnez votre propre réseau Wi-Fi, par exemple Ma Maison (photo fournie uniquement à titre de référence).

⑬ Saisissez le mot de passe de votre routeur Wi-Fi et cliquez sur OK ;

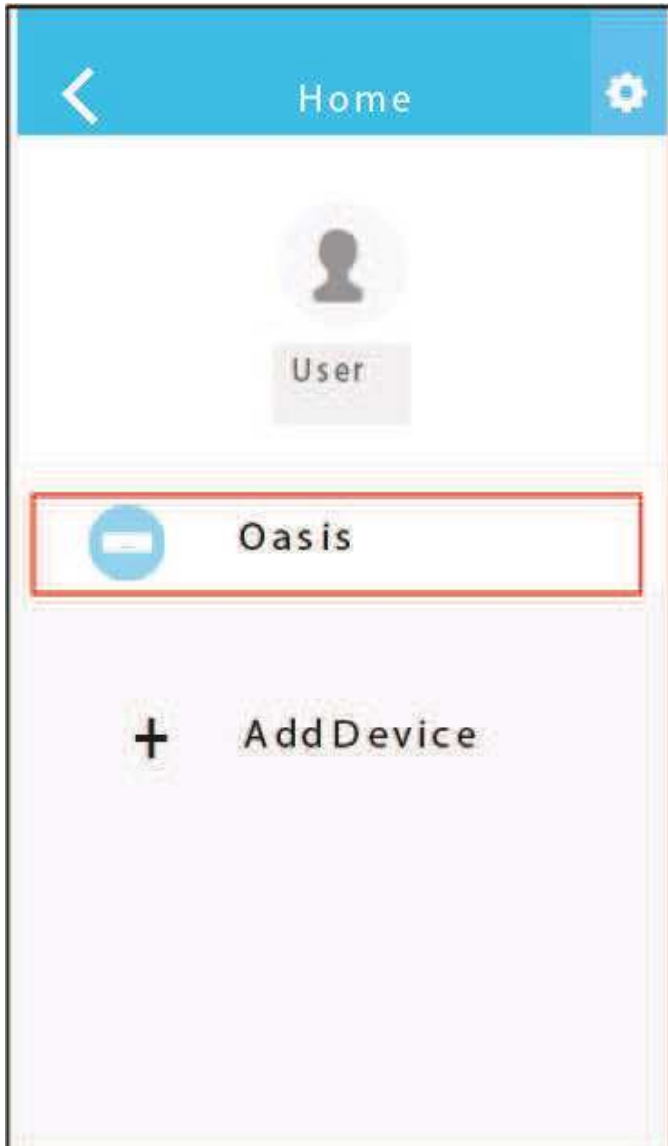

⑭ La configuration a réussi, vous pouvez voir apparaître l'appareil dans la liste.

NOTE:

- Lorsque la configuration du réseau est terminée, l'appli va afficher des mots signaux à l'écran.
- En raison des différences d'un environnement Internet à l'autre, il se peut que le statut du périphérique soit toujours sur « déconnecté ». Si cela se produit, il sera nécessaire de rafraîchir la liste de périphériques de l'appli et de s'assurer que le statut du périphérique est passé sur « connecté ». L'utilisateur peut aussi mettre l'unité hors tension et à nouveau sous tension. Le périphérique va prendre le statut « connecté » au bout de quelques minutes.

7 COMMENT UTILISER L'APPLI

Assurez-vous que tant votre périphérique mobile que votre unité sont connectés à l'Internet avant d'utiliser l'appli pour commander l'unité via l'Internet. Voici la marche à suivre pour cela.



① Saisissez votre compte et votre mot de passe et cliquez sur « Authentification »



② Sélectionnez l'unité cible à saisir dans l'interface de commande principale.



- ③ L'utilisateur peut commander le statut marche/arrêt de l'unité, le mode de fonctionnement, la température, la vitesse du ventilateur et ainsi de suite.

NOTE:

Toutes les fonctions de l'appli ne sont pas disponibles sur l'unité.

Par exemple : ECO, Turbo, fonction gauche et droite, fonction haut et bas. Veuillez consulter le manuel de l'utilisateur pour trouver plus d'informations.

8 FONCTIONS SPÉCIALES

Inclut : Timer on, Timer off, 8°C Heat, Sleep, Check.

NOTE : Si l'unité ne prend pas la fonction précédente en charge, la fonction sera masquée dans la liste de fonctions.

- **Timer on/ Timer off**

L'utilisateur peut programmer chaque semaine un arrêt/redémarrage de l'unité à un moment donné. Il peut également choisir la circulation pour assurer un contrôle hebdomadaire de l'unité.

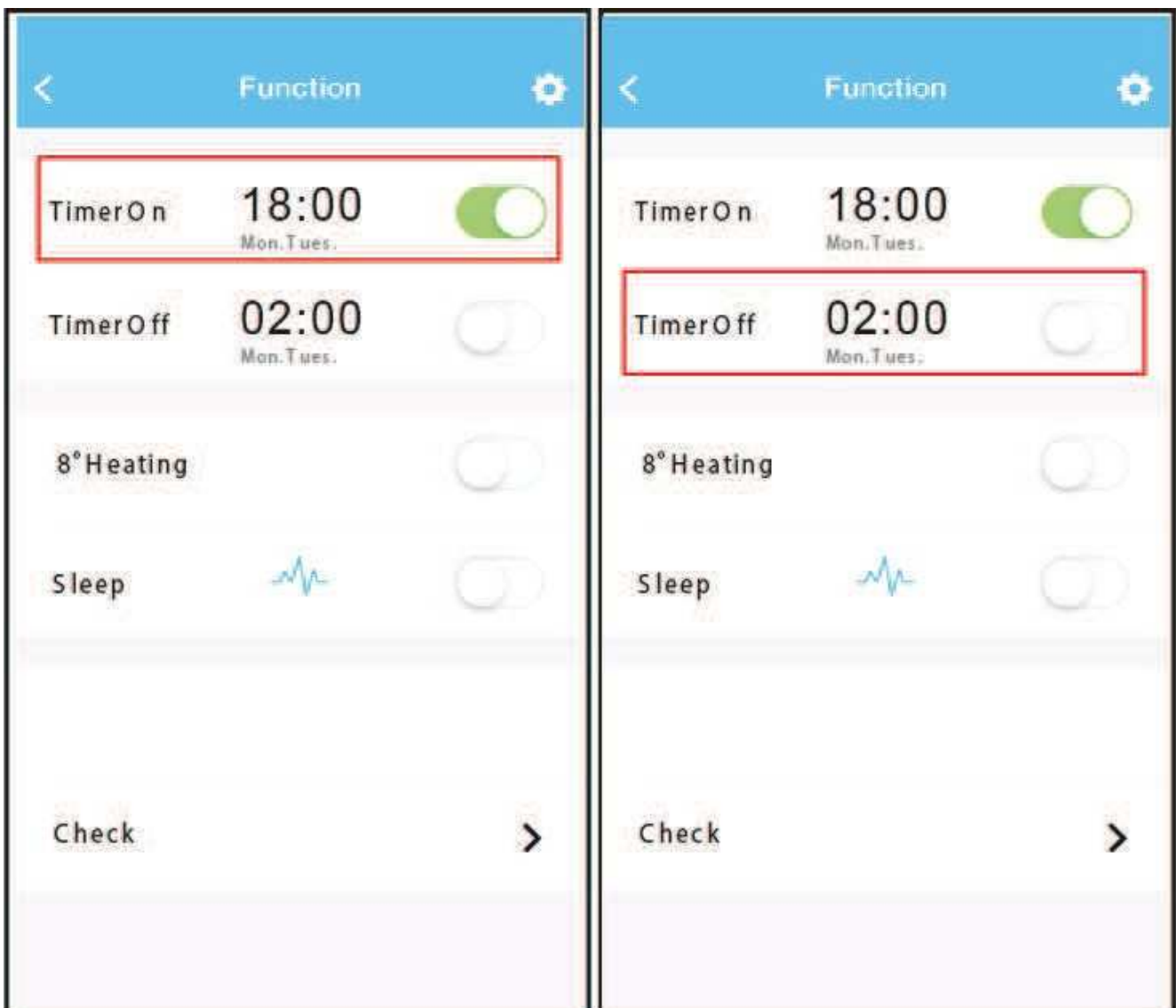

Timer On OK

08	48
09	49
10	SO
11	51

Repeat
Mon.Tue

Repeat

Monday

Tuesday O

Wednesday

Thursday

Friday

Saturday

Sunday

- **8°C Heat**

L'utilisateur peut laisser l'unité passer sous 8° C d'un simple clic. Lorsqu'il n'y a personne à la maison, cette fonction peut protéger vos meubles des dégâts dus au gel.

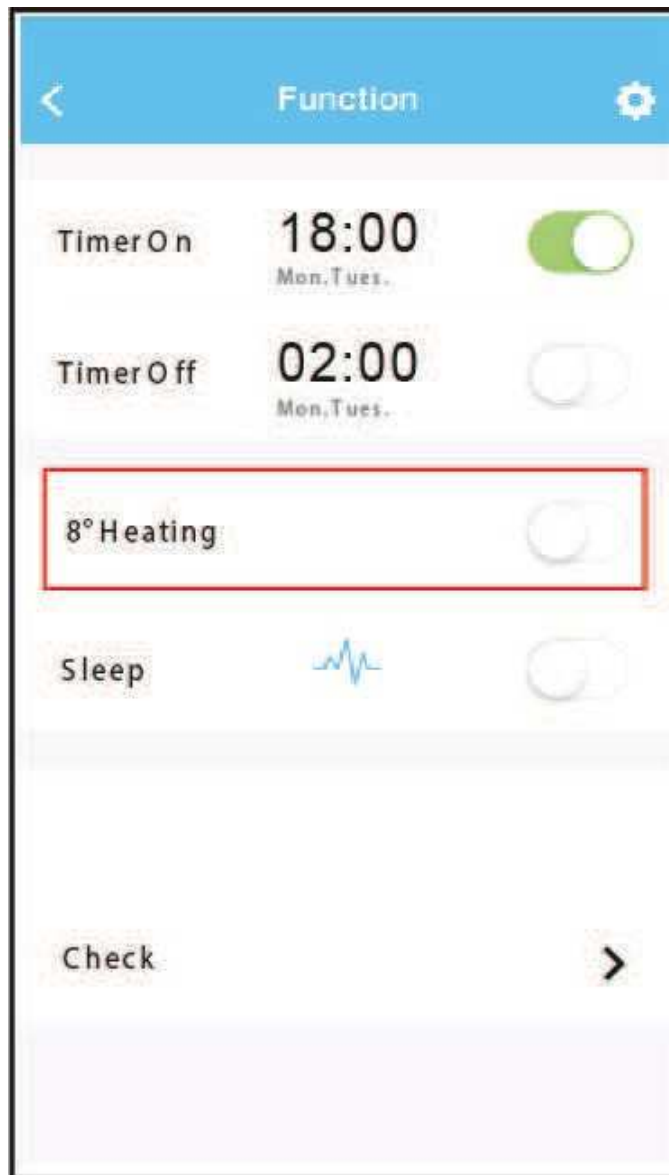

- **Sleep**

L'utilisateur peut personnaliser son confort de sommeil en paramétrant une température cible.

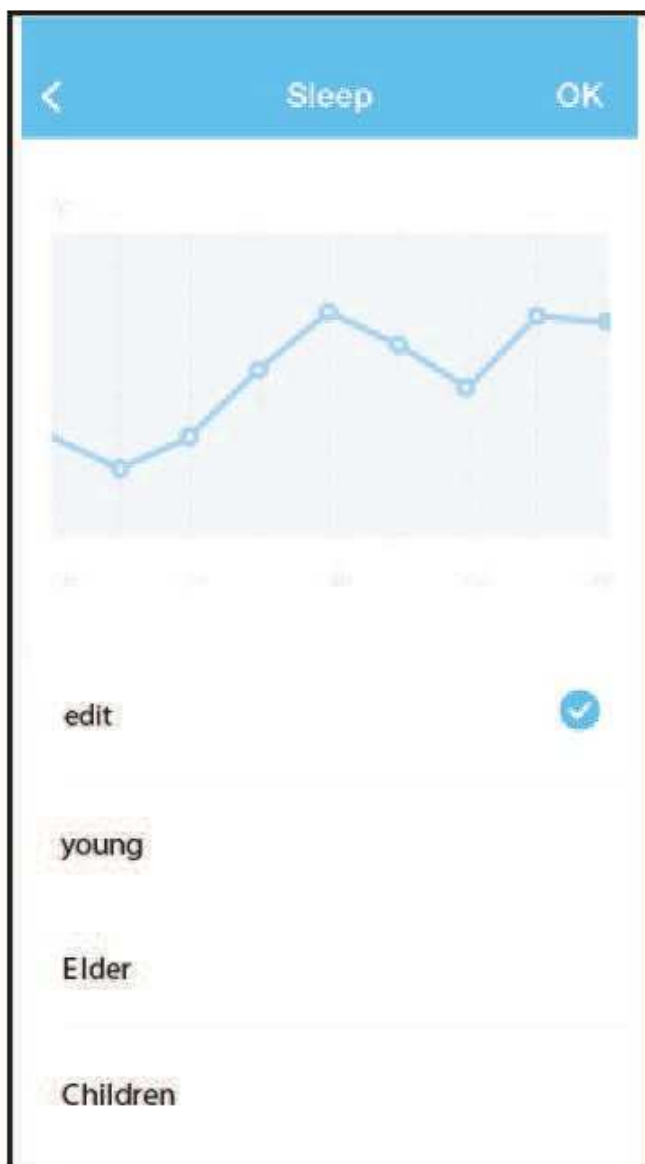

- **Check**

L'utilisateur peut tout simplement vérifier le statut de fonctionnement de l'unité avec cette fonction. En terminant cette procédure, il peut obtenir l'affichage des éléments normaux, des éléments anormaux et des informations détaillées.

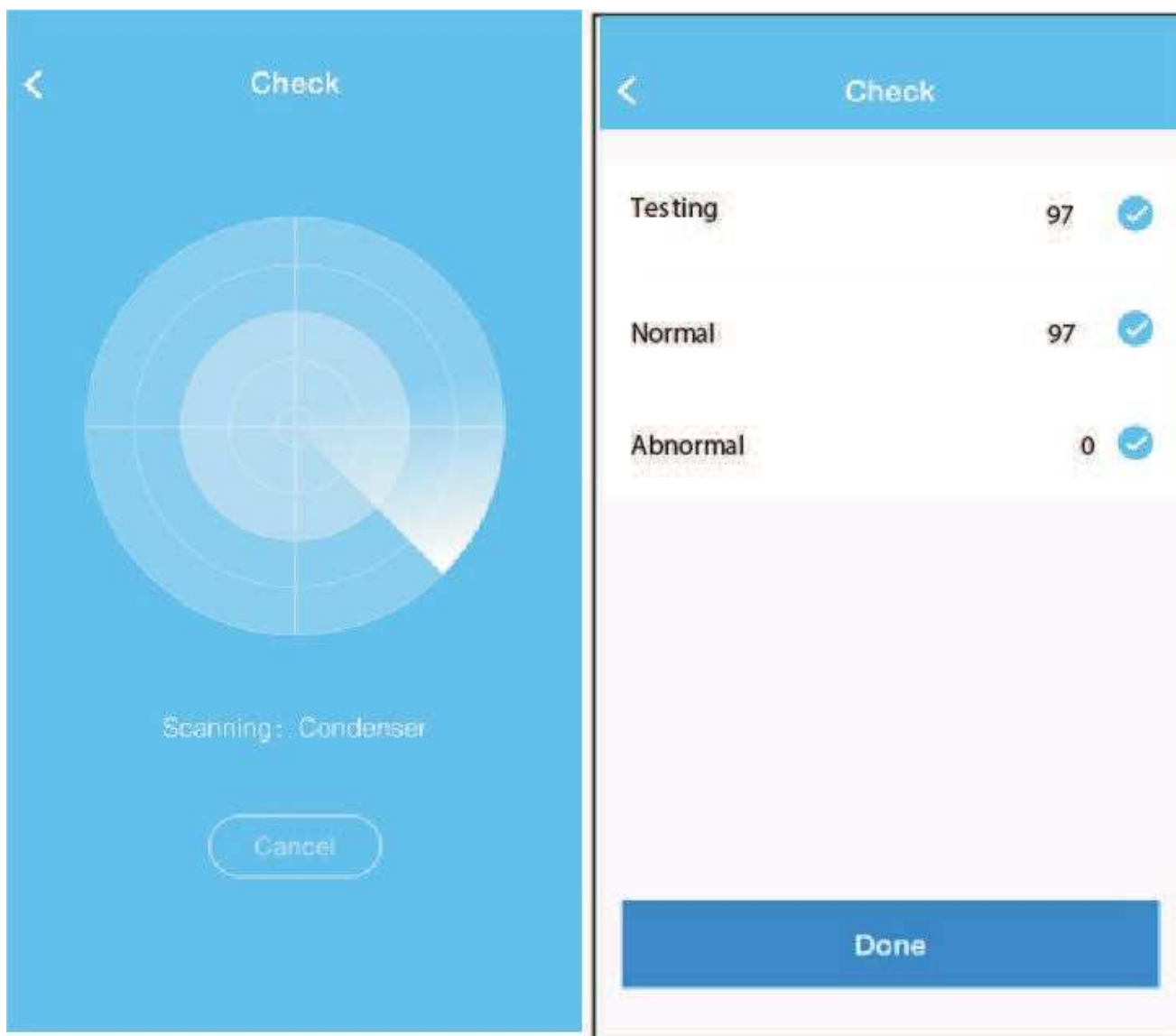

Detail

Abnormal:O

Normal :97

Compressor frequency

Compressor current

Outdoor machine current

Evaporator temperature

Condenser temperature

Exhaust temperature

Outdoor temperature

ATTENTION :

- Cet appareil est conforme au chapitre 15 des règles FCC et RSS-210 des domaines des sciences et de l'industrie du Canada. Son fonctionnement est soumis aux conditions suivantes : (1) cet appareil ne peut causer d'interférences nuisibles et (2) cet appareil doit accepter toute interférence reçue, y compris des interférences qui peuvent provoquer un fonctionnement non désiré.
- Utilisez l'appareil uniquement en parfait état et en respectant les instructions de service. Ce dispositif répond aux limites de la FCC et de l'IC sur l'exposition aux rayonnements établies pour un environnement non contrôlé. Afin d'éviter la possibilité de dépasser les limites de la FCC et de l'IC sur l'exposition aux fréquences radio, la proximité humaine de l'antenne ne sera pas inférieure à 20 cm (8 pouces) en fonctionnement normal).
- Tout changement et/ou toute modification non expressément approuvés par la partie responsable de la conformité pourraient annuler l'autorisation pour l'utilisateur d'utiliser cet équipement.

NOTE :

L'entreprise décline toute responsabilité en cas de problèmes dus à l'Internet, au routeur Wi-Fi ou à des appareils intelligents.

Veillez contacter le fournisseur d'origine pour plus d'aide.